

# SMA Semi-Rigid Cable Connectors

## 5319

Straight cable male  
(without contact)

Tensolite Part No.	Cable type
5319	.141

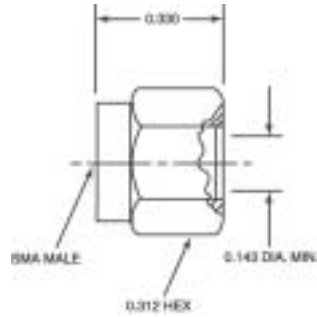

Refer to Assembly Instruction 123 on page 198

## 5319-1, 5317

Straight cable male  
(without contact)

Tensolite Part No.	Cable type
5319-1	.141
5317	.141

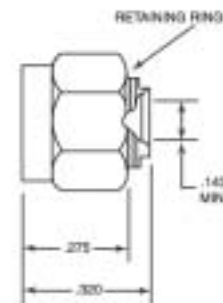
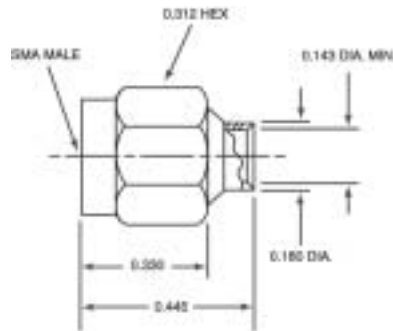

Refer to Assembly Instruction 222 on page 206

5319-1 without contact

5317 with retractable coupling nut

## 5319-0-1

SMA male anti-torque nut to Ø .141  
Semi-Rigid cable (no contact)

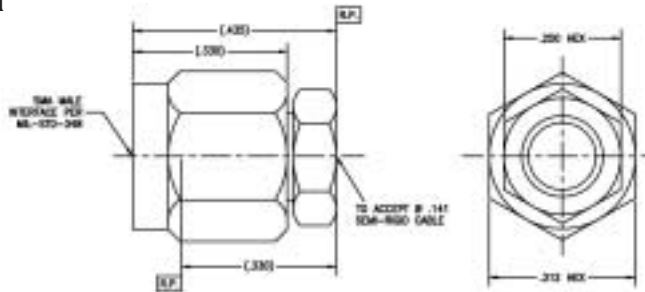

Consult factory for Assembly Instructions

## 5285-1 thru -3 & 5285-5CC

Straight cable male (with contact)

Tensolite Part No.	"A"	Cable type
5285-1	.143 min.	.141
5285-2	.088 min.	.085
5285-3	.143 min.	.141*
5285-5CC	.048 min.	.047

\*Microporous

5285-5CC Center contact is captivated

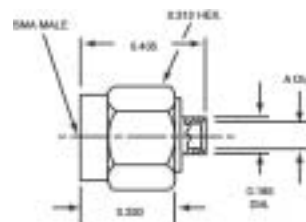

5285-1,2,3

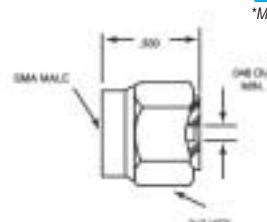

5285-5CC

Refer to Assembly Instruction 111 on page 186

# SMA Semi-Rigid Cable Connectors

## 5285-0-4

SMA male anti-torque straight to Ø .085 Semi-Rigid cable

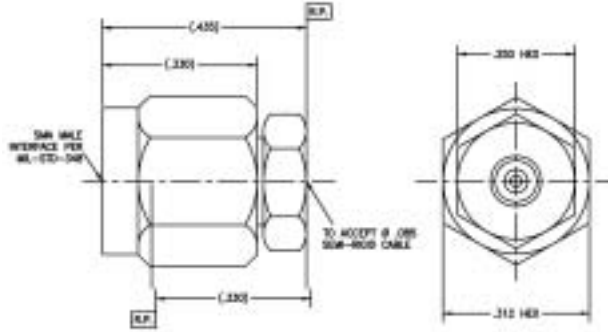

Consult factory for Assembly Instructions

## 5286-1 thru -3

Straight cable female

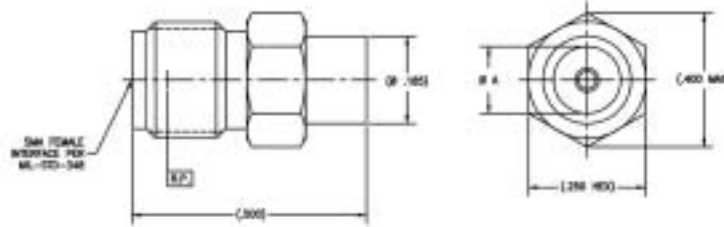

Tensolite Part No.	"A"	Cable type
5286-1	.143 min.	.141
5286-2	.088 min.	.085
5286-3	.143 min.	.141*

\*Microporous .185 and "A" diameters will be gold plated on SF units for solderability.

Refer to Assembly Instruction 113 on page 188

## 5289-1 thru -3

Bulkhead feedthrough cable female

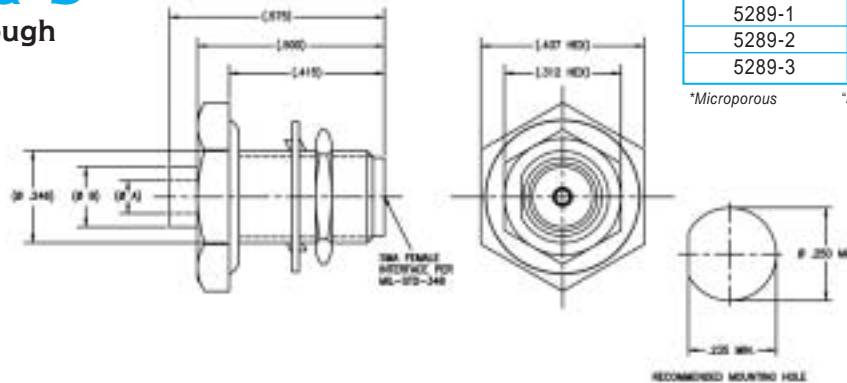

Tensolite Part No.	"A"	"B"	Cable type
5289-1	.143 min.	.250	.141
5289-2	.088 min.	.185	.085
5289-3	.143 min.	.250	.141*

\*Microporous "A" and "B" diameters will be gold plated on SF units for solderability.

Refer to Assembly Instruction 113 on page 188

## 5224-2CC

SMA female 4 hole flange (.500 sq) mount to Ø .085 Semi-Rigid cable

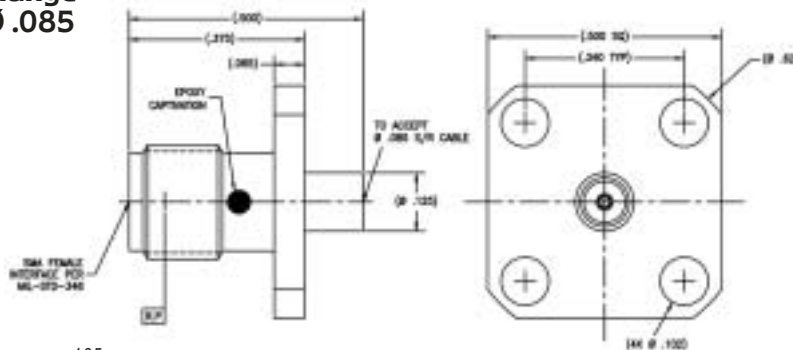

Tensolite Part No.	Cable type
5224-2CC	.085

Center conductor is captivated. .088 and .125 diameters will be gold plated on SF units for solderability.

Refer to Assembly Instruction 120 on page 195

**Tensolite**

A CARLISLE Company

Call: 866-282-4708

Website: [www.tensolite.com](http://www.tensolite.com)

# SMA Semi-Rigid Cable Connectors

SMA Semi-Rigid Cable Connectors

## 5228-1 thru -3 & 5228-5CC

Flange mount cable female

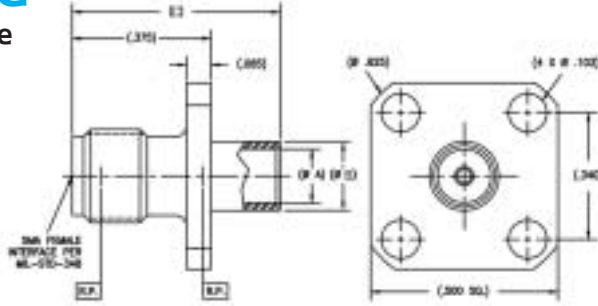

Tensolite Part No.	"A"	"B"	"C"	Cable type
5228-1	.143 min.	.185	.560	.141
5228-2	.088 min.	.125	.500	.085
5228-3	.143 min.	.185	.560	.141*
5228-5CC	.048 min.	.125	.440	.047

\*Microporous "A" and "B" diameters will be gold plated on SF units for solderability. Add suffix CC to Part No. for captivated contact.

Refer to Assembly Instruction 132 on page 201

## 5229-1 thru -3 & 5229-5CC

Two hole flange mount cable female

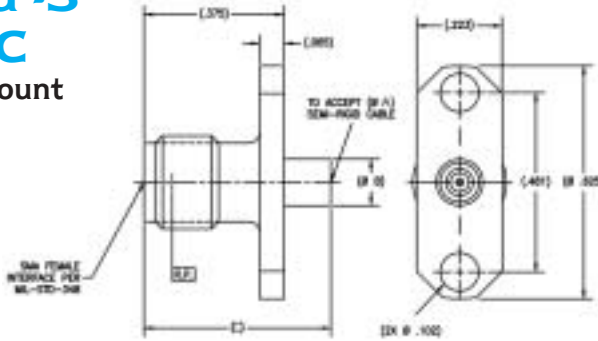

Tensolite Part No.	"A"	"B"	"C"	Cable type
5229-1	.143 min.	.185	.560	.141
5229-2	.088 min.	.125	.500	.085
5229-3	.143 min.	.185	.560	.141*
5229-5CC	.048 min.	.100	.440	.047

\*Microporous "A" and "B" diameters will be gold plated on SF units for solderability. Add suffix CC to Part No. for captivated contact.

5229-1,2,3, Refer to Assembly Instruction 113 on page 188

## 5225-2CC

Two hole flange mount cable female

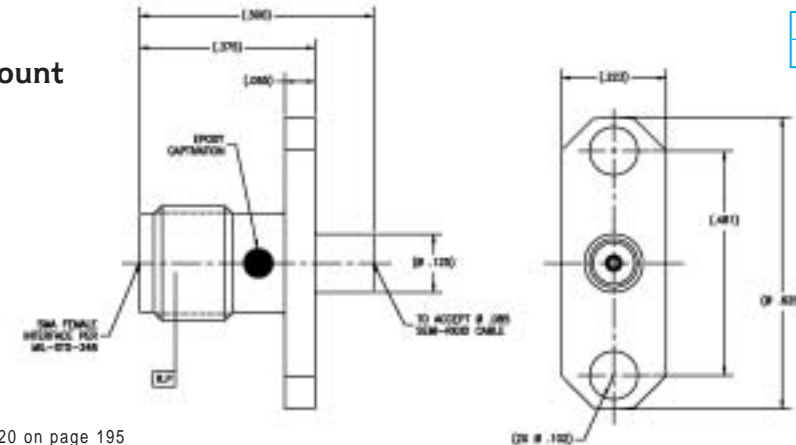

Tensolite Part No.	Cable type
5225-2CC	.085

Center conductor is captivated. .088 and .125 diameters will be gold plated on SF units for solderability.

Refer to Assembly Instruction 120 on page 195

## 5850-1 thru -3CC

Right Angle cable male

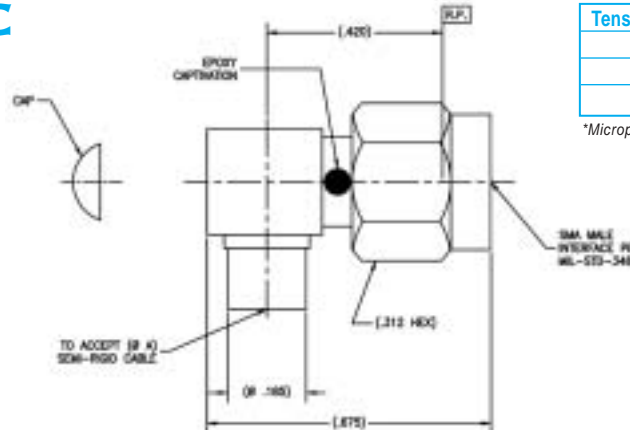

Tensolite Part No.	"A"	Cable type
5850-1CC	.143 min.	.141
5850-2CC	.088 min.	.085
5850-3CC	.143 min.	.141*

\*Microporous Center conductor is captivated. Coupling nut will be passivated stainless steel on SF units.

Refer to Assembly Instruction 124 on page 199

**Tensolite**

A CARLISLE Company

Call: 866-282-4708

Website: [www.tensolite.com](http://www.tensolite.com)

Standard units are gold plated. Add suffix SF to Part Number for stainless steel finish.

# SMA Semi-Rigid Cable Connectors

## 5236-1 & 5236-2

Radius right Angle cable male

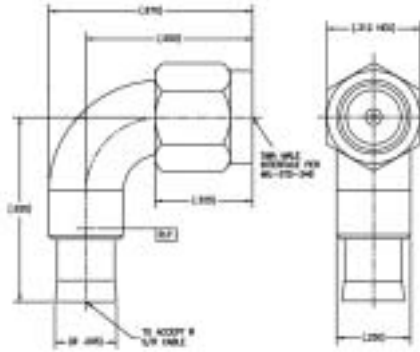

5236-1, Refer to Assembly Instruction 105 on page 180  
5236-2, Refer to Assembly Instruction 106 on page 181

Tensolite Part No.	Cable type
5236-1	.141
5236-2	.085

Coupling nut will be passivated stainless steel on SF units.

Add suffix CC to Part No. for captivated contact.

## 5235-1 & 5235-2

Radius right Angle cable female

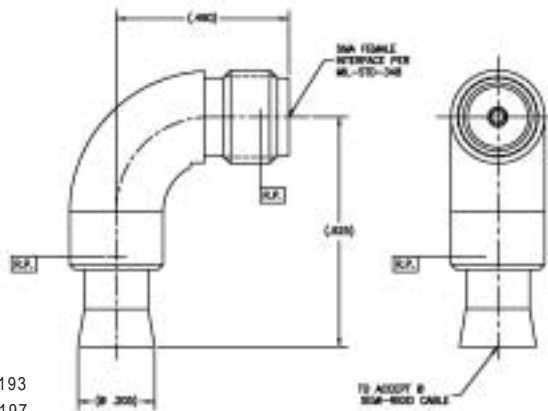

5235-1, Refer to Assembly Instruction 118 on page 193  
5235-2, Refer to Assembly Instruction 122 on page 197

Tensolite Part No.	Cable type
5235-1	.141
5235-2	.085

5235-1: .143 and .205 diameters will be gold plated on SF units for solderability.  
5235-2: .088 and .185 diameters will be gold plated on SF units for solderability.

Add suffix CC to Part No. for captivated contact.

## 5161-1 & 5161-2

Radius right angle flange mount cable female

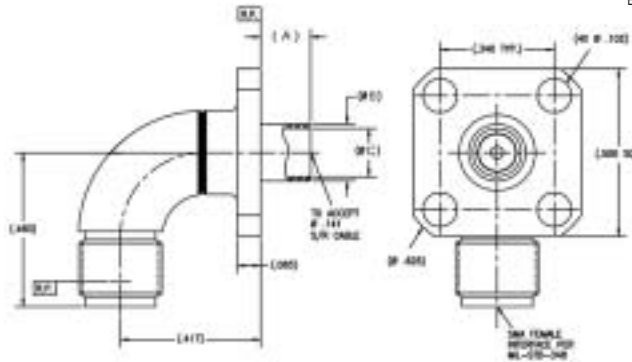

Tensolite Part No.	"A"	"B"	"C"	Cable type
5161-1	.150 min.	.170	.143	.141
5161-2	.100 min.	.125	.088	.085

"B" and "C" diameters will be gold plated on SF units for solderability.  
Add suffix CC to Part No. for captivated contact.

5161-1, Refer to Assembly Instruction 103 on page 178  
5161-2, Refer to Assembly Instruction 104 on page 179

# SMA Phase Adjustable SMA Connector

## 5999-1CCSF & 5999-2CCSF

SMA male straight phase adjustable to Semi-Rigid cable

Tensolite Part No.	"A"	Cable type
5999-1CCSF	.143 min.	.141
5999-2CCSF	.088 min.	.085

Physical length change per revolution of adjustment nut: .018 inch  
 Electrical length change per revolution of adjustment nut: .0127  
 Max. change in physical length: .160 ± .010 inch of air  
 Max. change in electrical length: .103 ± .007 inch of air  
 Standard units are passivated; "A" & "B" diameters will be gold plated for solderability.  
 Center contact is captivated

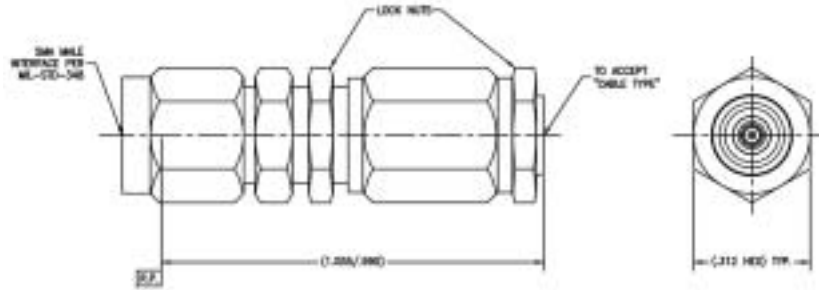

Refer to Assembly Instruction 178, 179 on pages 204, 205

FREQUENCY (GHZ)	ELECTRICAL LENGTH FULLY CLOSED	ELECTRICAL LENGTH FULLY OPEN	MAX. DEGREE CHANGE (PHASE SHIFT)	DEGREES PHASE CHANGE PER REVOLUTION OF ADJUSTMENT NUT
2	53°	63°	10°	10.9°
4	106°	126°	20°	2.19°
6	159°	189°	29°	3.29°
8	212°	252°	39°	4.39°
10	265°	315°	49°	5.49°
12	318°	378°	59°	6.58°
14	371°	442°	68°	7.68°
16	424°	505°	78°	8.78°
18	477°	568°	88°	9.87°
20	530°	630°	97°	10.95°
22	583°	694°	107°	11.38°
24	636°	757°	117°	13.14°
26	689°	820°	127°	14.23°

### DESCRIPTION

The Tensolite 5999 is an adjustable coaxial phase shifter, covering DC through 26 GHz. Inserting this device into a cable/connector line provides continuously variable phase shift (up to 126 deg. at 26 GHz) allowing adjustment of the the electrical separation between the other components in a system.

Made of passivated stainless steel, the 5999 incorporates an SMA Male connector, spacing assembly, and a positive resettable locking mechanism.

### ELECTRICAL PERFORMANCE

Impedance: 50 OHMS over full adj. range  
 Frequency Range: DC-26 GHz

#### Working Voltage:

At Sea Level: 500 VRMS

At 70,000 Ft: 125 VRMS

VSWR: 1.05 + .008f (GHz) Max.

R.F. Insertion Loss: .05 x √F (GHz)

Insulation Resistance: 5000 Megohms Min.

Dielectric Withstanding Voltage: 1500 VRMS

R.F. High Potential Withstanding Voltage:

670 RMS @ 5 MHz to 7.5 MHz

R.F. Leakage: -90 db

#### Corona Level:

Voltage: 375

Altitude: 70,000 Ft.

#### Contact Resistance:

CENTER CONDUCTOR:

Before Environmental: 3.0 Milliohms Max.

After Environmental: 4.0 Milliohms Max.

OUTER CONDUCTOR:

Before Environmental: 2.0 Milliohms Max.

After Environmental: Not Applicable

Permeability: Less Than 2.0 Mu



# SMA Semi-Rigid Cable Receptacles

## Connector receptacle 4 hole flange

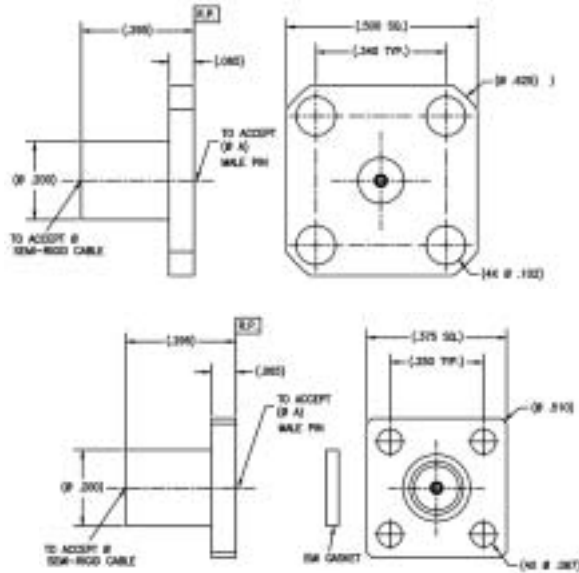

Refer to Assembly Instruction 224 on page 208

Tensolite Part No.	EMI gasket	Flange size	Cable type
5810-1CC thru 5810-6CC	none	.500 4 hole	.141
5811-2CC thru 5811-6CC	none	.500 4 hole	.085
5812-2CC thru 5812-6CC	none	.500 4 hole	.047
5813-2CC thru 5813-6CC	with	.500 4 hole	.085
5814-2CC thru 5814-6CC	with	.500 4 hole	.047
5815-1CC thru 5815-6CC	none	.375 4 hole	.141
5816-2CC thru 5816-6CC	none	.375 4 hole	.085
5817-2CC thru 5817-6CC	none	.375 4 hole	.047
5818-2CC thru 5818-6CC	with	.375 4 hole	.085
5819-2CC thru 5819-6CC	with	.375 4 hole	.047

### Pin Size Selection Chart

Dash number	-1cc	-2cc	-3cc	-4cc	-5cc	-6cc
Dim. "A" = ± .0005	.036	.020	.01	.012	.015	.018

Center connector is captivated

## Connector receptacle 4 hole flange

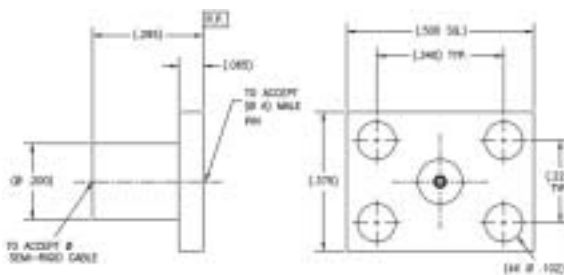

Refer to Assembly Instruction 224 on page 208

Tensolite Part No.	EMI gasket	Flange size	Cable type
5820-1CC thru 5820-6CC	none	.500 X .375 4 hole	.141
5821-2CC thru 5821-6CC	none	.500 X .375 4 hole	.085
5822-2CC thru 5822-6CC	none	.500 X .375 4 hole	.047
5823-2CC thru 5823-6CC	with	.500 X .375 4 hole	.085
5824-2CC thru 5824-6CC	with	.500 X .375 4 hole	.047

### Pin Size Selection Chart

Dash number	-1cc	-2cc	-3cc	-4cc	-5cc	-6cc
Dim. "A" = ± .0005	.036	.020	.01	.012	.015	.018

Center connector is captivated

## Connector receptacle 2 hole flange

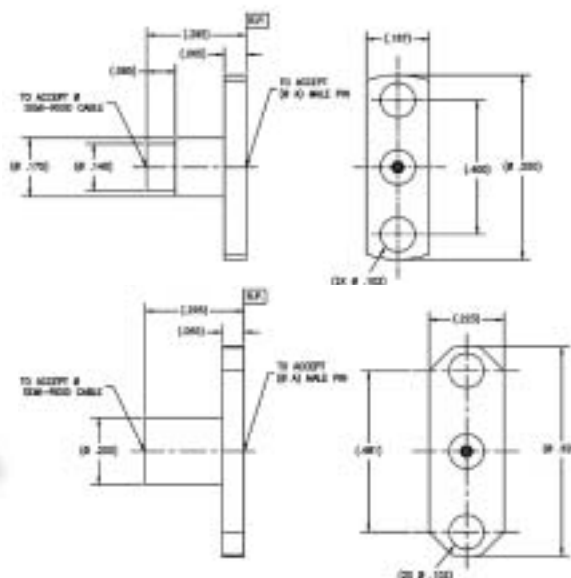

Refer to Assembly Instruction 224 on page 208

Tensolite Part No.	EMI gasket	Flange size	Cable type
5785-1CC thru 5785-6CC	none	.550 X .187 2 hole	.141
5786-2CC thru 5786-6CC	none	.550 X .187 2 hole	.085
5787-2CC thru 5787-6CC	none	.550 X .187 2 hole	.047
5790-2CC thru 5790-6CC	none	.625 X .223 2 hole	.141
5791-1CC thru 5791-6CC	none	.625 X .223 2 hole	.085
5792-2CC thru 5792-6CC	none	.625 X .223 2 hole	.047
5793-2CC thru 5793-6CC	with	.625 X .223 2 hole	.085
5794-2CC thru 5794-6CC	with	.625 X .223 2 hole	.047

### Pin Size Selection Chart

Dash number	-1cc	-2cc	-3cc	-4cc	-5cc	-6cc
Dim. "A" = ± .0005	.036	.020	.01	.012	.015	.018

Center connector is captivated

# SMA Flexible Cable Connectors

## 5730

**Straight cable male  
(crimp or solder  
attachment)**

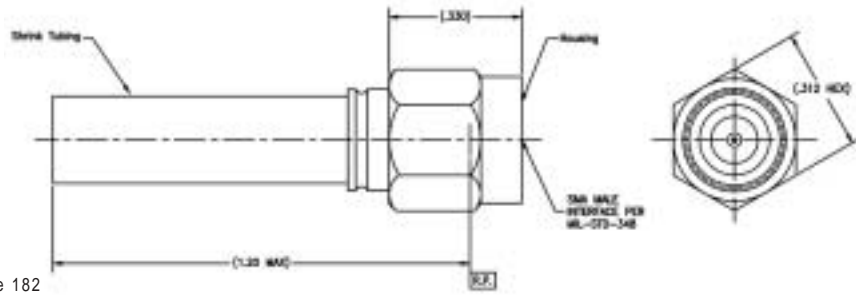

5730-1, Refer to Assembly Instruction 107 on page 182  
5730-2, Refer to Assembly Instruction 108 on page 183

Tensolite Part No.	Cable type
5730-1	RG 55, 58, 141, 142, 223, 303, 400
5730-2	RG 174, 188, 316, 179, 187

## 5733

**SMA male straight anti-torque  
to LLF1087 flex cable**

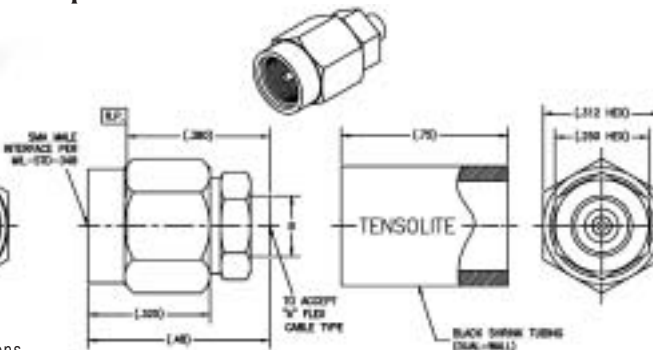

Consult factory for Assembly Instructions

Tensolite Part No.	"A" Cable Types	ØB
5733-1	LLF-1087	
5733-1SF	T-Flex 405HF and Microflex Ø .095	(.163)
5733-2	LLF-2105S	(.163)
5733-3	LLF-1141	(.185)
5733-3SF	T-Flex 402HF	
5733-4CCSF	LLF301	(.220)
5733-5	M17/152-00001	(.163)
5733-5SF		
5733-6	LLF-2078	(.163)
5733-6SF		

## 5720

**Straight cable female  
(crimp or solder  
attachment)**

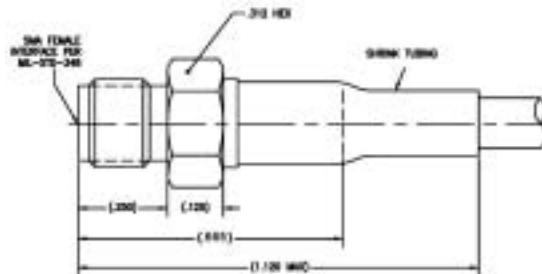

Refer to Assembly Instruction 109 on page 184

Tensolite Part No.	Cable type
5720-1	RG 55, 142, 223, 400, 58, 141, 303
5720-1SF	RG 55, 142, 223, 400, 58, 141, 303
5720-2	RG 174, 188, 316, 179, 187
5720-2SF	RG 174, 188, 316, 179, 187

## 5721

**Bulkhead feedthrough cable  
female (crimp or solder  
attachment)**

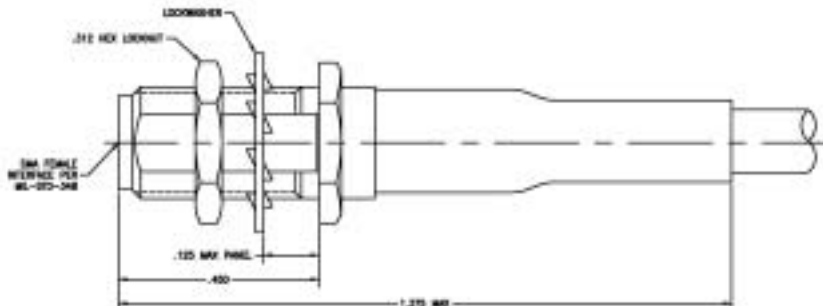

Refer to Assembly Instruction 110 on page 185

Tensolite Part No.	Cable type
5721-1	RG 55, 58, 141, 142, 223, 303, 400
5721-2	RG 174, 188, 316, 179, 187

**Tensolite**

A CARLISLE Company

Call: 866-282-4708 Website: [www.tensolite.com](http://www.tensolite.com)

## 5851

Right angle cable male  
(crimp or solder attachment)

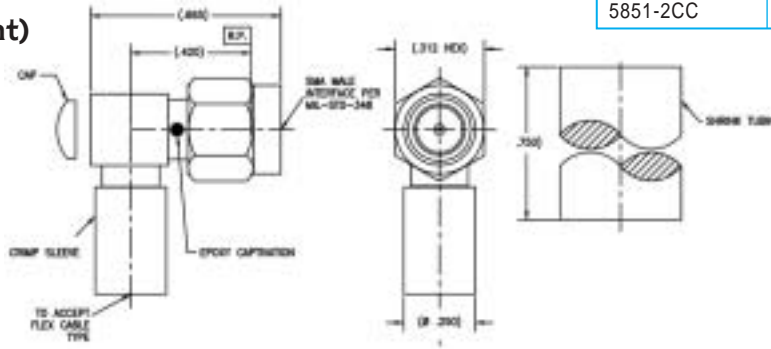

Tensolite Part No.	Cable type
5851-1CC	RG 55, 58, 141, 142, 223, 303, 400
5851-2CC	RG 174, 188, 316, 179, 187

Center conductor is captivated

Refer to Assembly Instruction 101 on page 176

## 5750

Radius right angle cable male

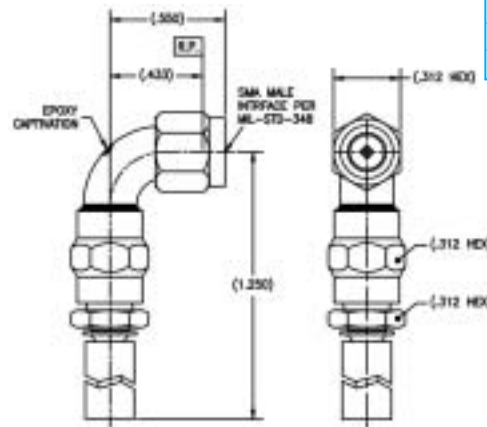

Tensolite Part No.	Cable type
5750-1CC	RG55, RG58, RG141, RG142, RG223, RG303, RG400
5750-2CC	RG174, RG179, RG187, RG188, RG316

Center conductor is captivated

Refer to Assembly Instruction 116 on page 191

## 5752

Radius right angle cable male

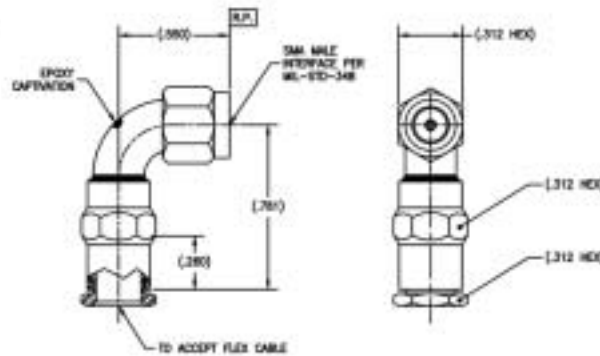

Tensolite Part No.	Cable type
5752-1CC	RG55, RG58, RG141, RG142, RG223, RG303, RG400
5752-2CC	RG174, RG179, RG187, RG188, RG316

Center conductor is captivated

Refer to Assembly Instruction 121 on page 196



## 5924CC, 5260CC, 5270CC, 5277CC

Flange mount female

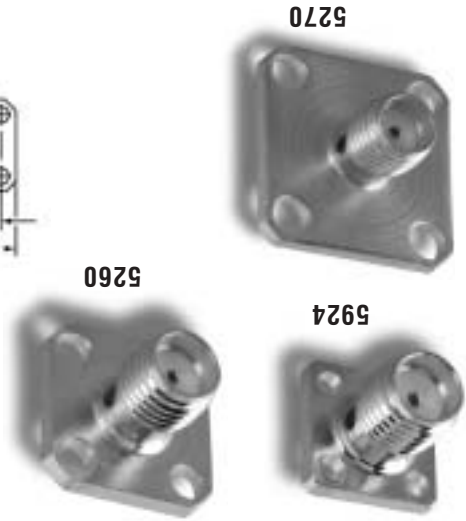

Flange Size	Tensolite Part No.
.375	5924CC
.500	5260CC
.687	5270CC
1.000	5277CC

Center conductor is captivated.

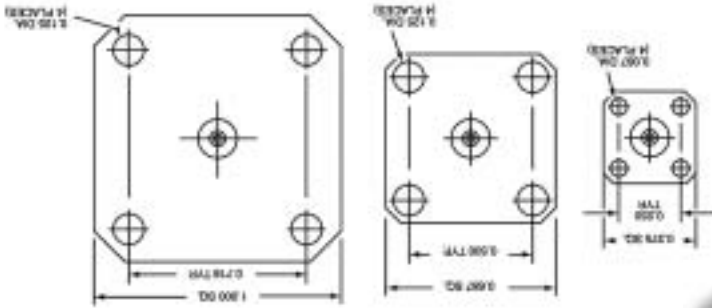
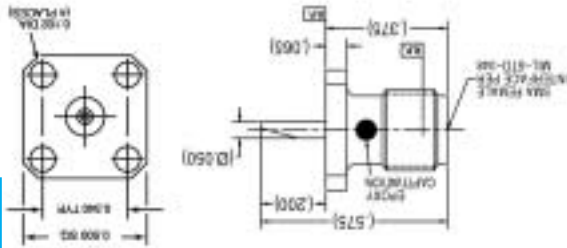

5924

5260

5270

Flange mount male

## 5339CC

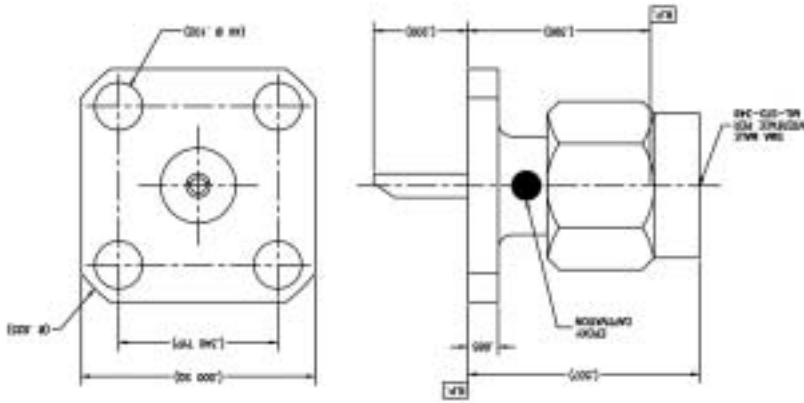

Center conductor is captivated.

## 5210

Two hole flange mount female

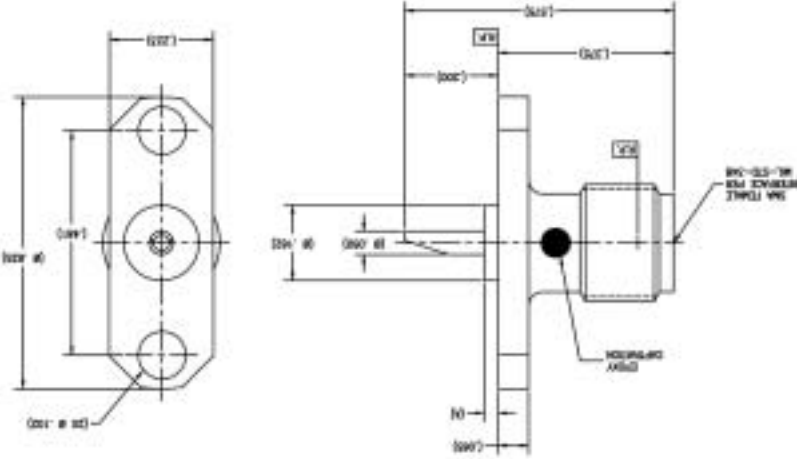

Center conductor is captivated.

Tensolite Part No.	"A"
5210-1CC	.000
5210-2CC	.020
5210-3CC	.030

# SMA Bulkhead & Panel Mount Solder Pot Terminations

## 5211CC

Two hole flange mount male

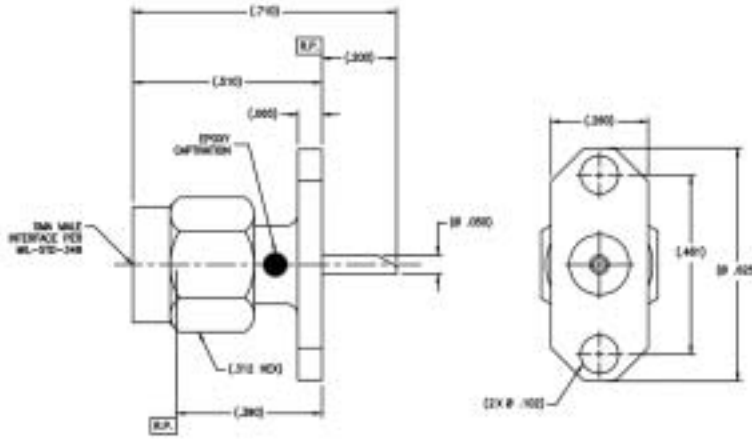

Center conductor is captivated.

SMA Bulkhead & Panel Mount Solder Pot Terminations

## 5430CC, 5424CC

Radius right angle flange mount female

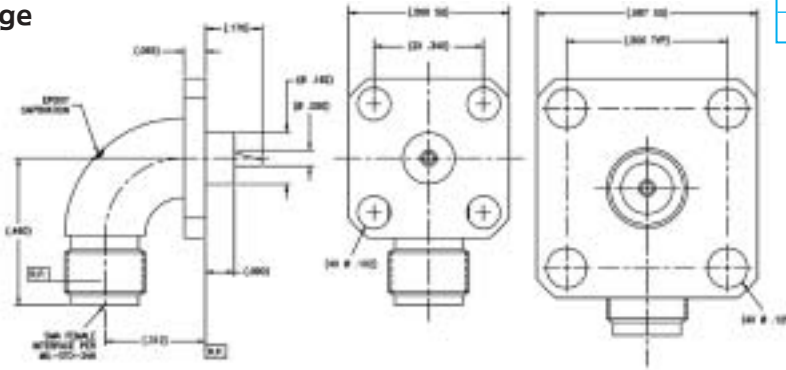

Tensolite Part No.	Flange Size
5430CC	.500
5424CC	.687

Center conductor is captivated.

## 5642CC, 5643CC

Radius right angle two hole flange mount female

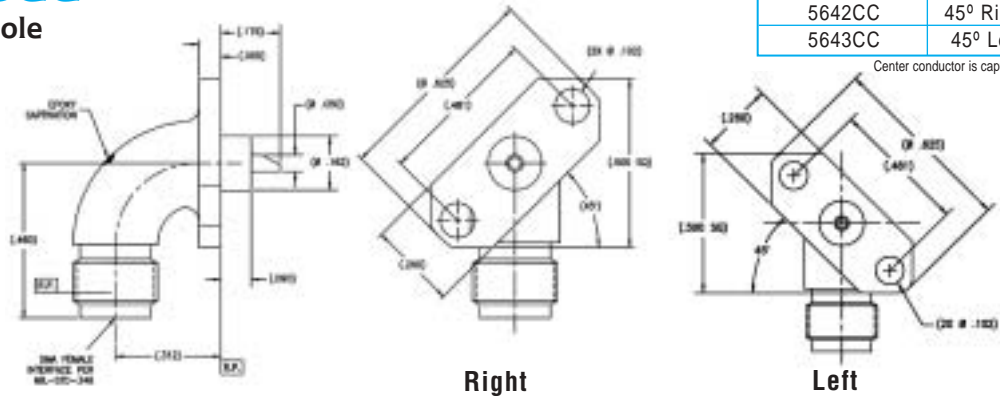

Tensolite Part No.	Flange Angle
5642CC	45° Right
5643CC	45° Left

Center conductor is captivated.

## 5432CC

Radius right angle flange mount male

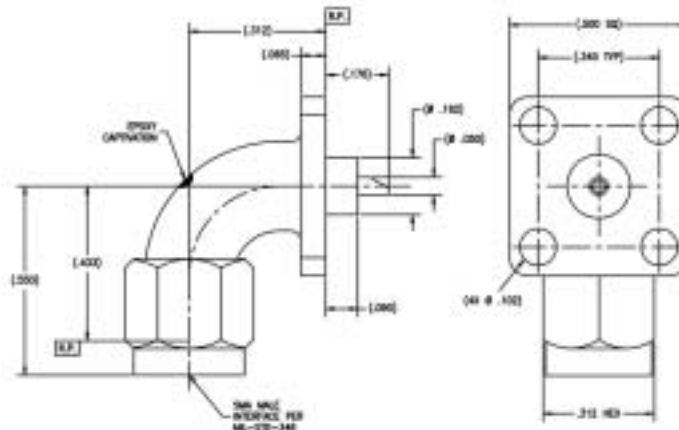

Center conductor is captivated.

Tensolite

A CARLISLE Company

Call: 866-282-4708

Website: [www.tensolite.com](http://www.tensolite.com)

Standard units are gold plated. Add suffix SF to Part Number for stainless steel finish.



# SMA Bulkhead & Panel Mount Solder Pot Terminations

## 5295CC

Bulkhead feedthrough female

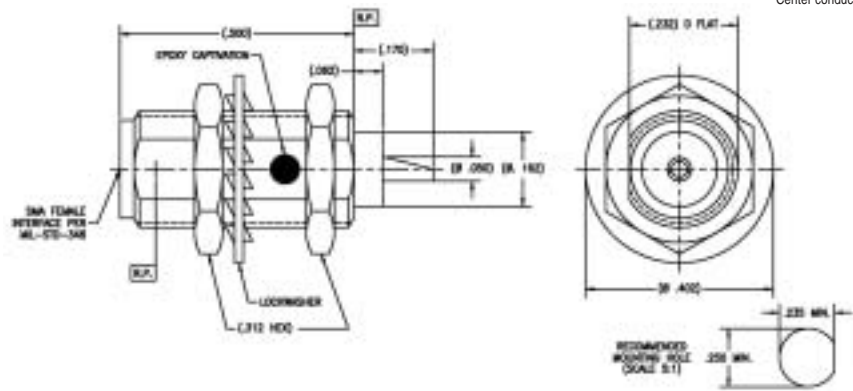

Center conductor is captivated

SMA Bulkhead & Panel Mount Solder Pot Terminations

## 5293CC

Bulkhead feedthrough female

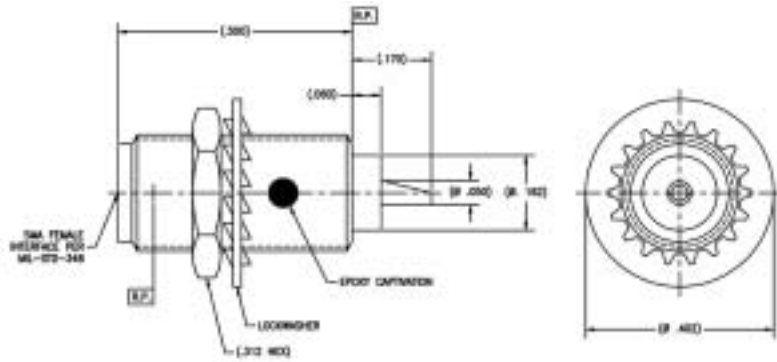

Center conductor is captivated

# SMA Bulkhead & Panel Mount Straight Terminations

**5921, 5220,  
5267, 5273**

Flange mount female

Tensolite Part No.	Flange Size
5921	.375
5220	.500
5267	.687
5273	1.000

Add suffix CC to Part No. for captivated contact.

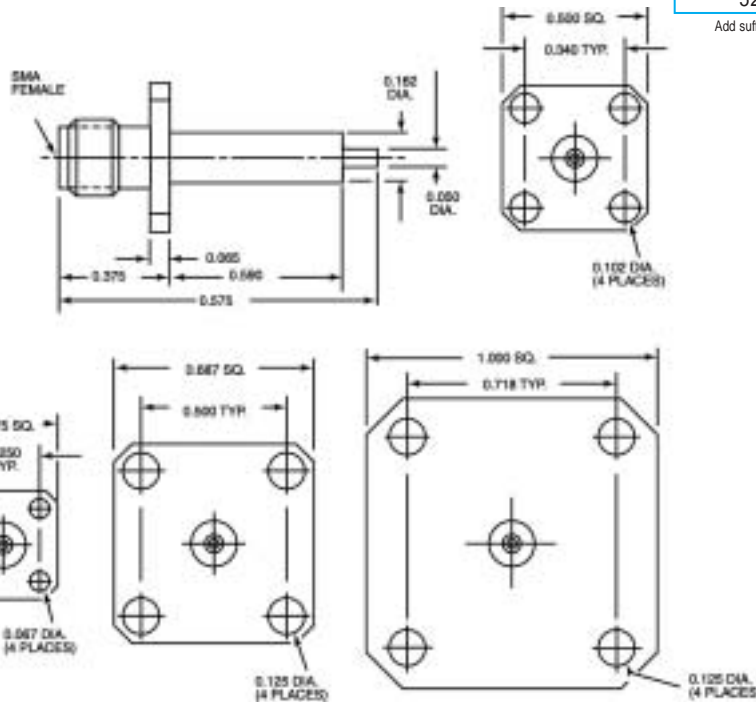

**5340**

Flange mount male

Add suffix CC to Part No. for captivated contact.

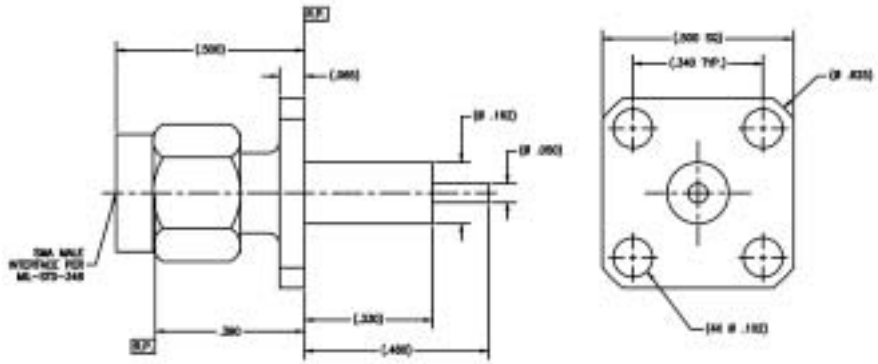

**5032**

Two hole flange mount female

Add suffix CC to Part No. for captivated contact.

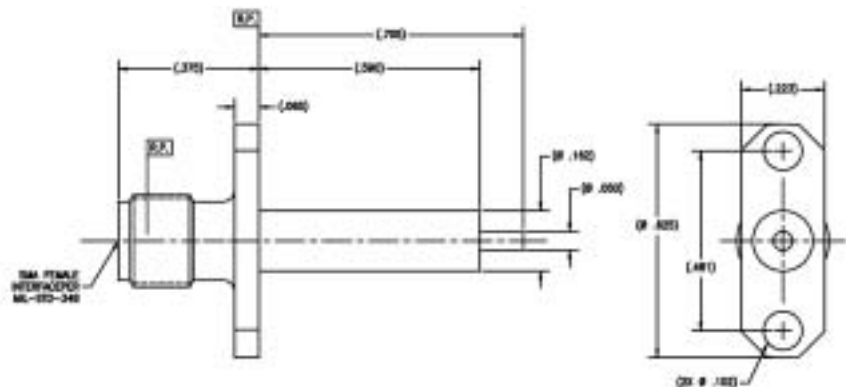

**Tensolite**

A CARLISLE Company

Call: 866-282-4708

Website: [www.tensolite.com](http://www.tensolite.com)

Standard units are gold plated. Add suffix SF to Part Number for stainless steel finish.

SMA Bulkhead & Panel Mount Straight Terminations



# SMA Bulkhead & Panel Mount Straight Terminations

## 5341

Two hole flange mount male

Add suffix CC to Part No. for captivated contact.

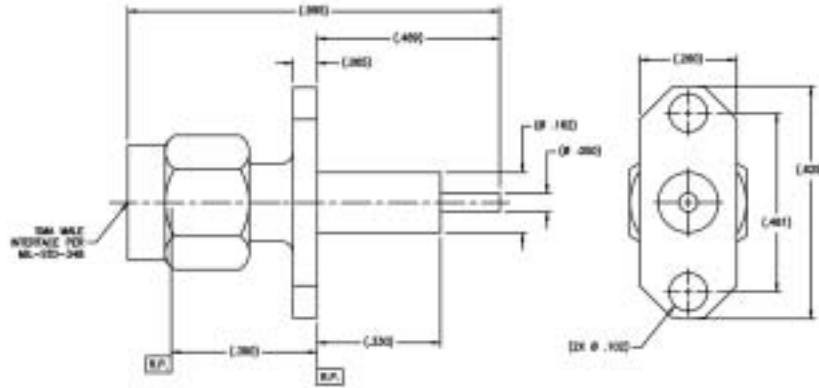

## 5294CC

Bulkhead feedthrough female

Center conductor is captivated.

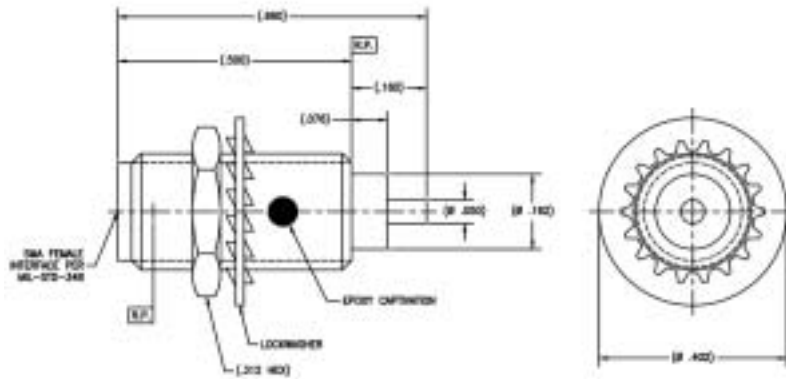

## 5691

Flange mount female

Add suffix CC to Part No. for captivated contact.

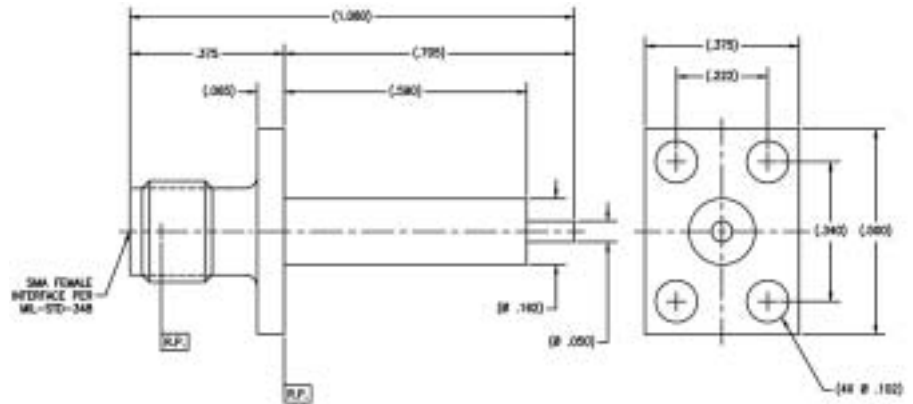

## 5890

Panel press mount female

Add suffix CC to Part No. for captivated contact.

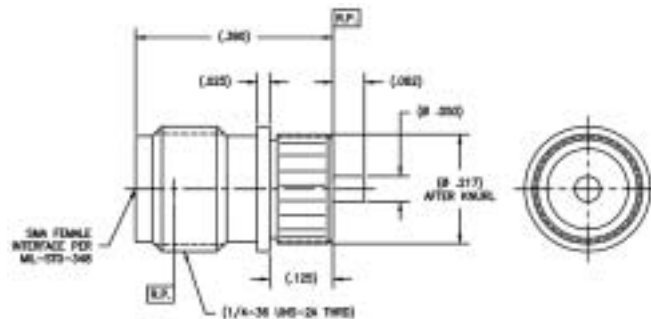

# SMA Bulkhead & Panel Mount Straight Terminations

## 5450, 5423, 5803

Radius right angle flange mount female

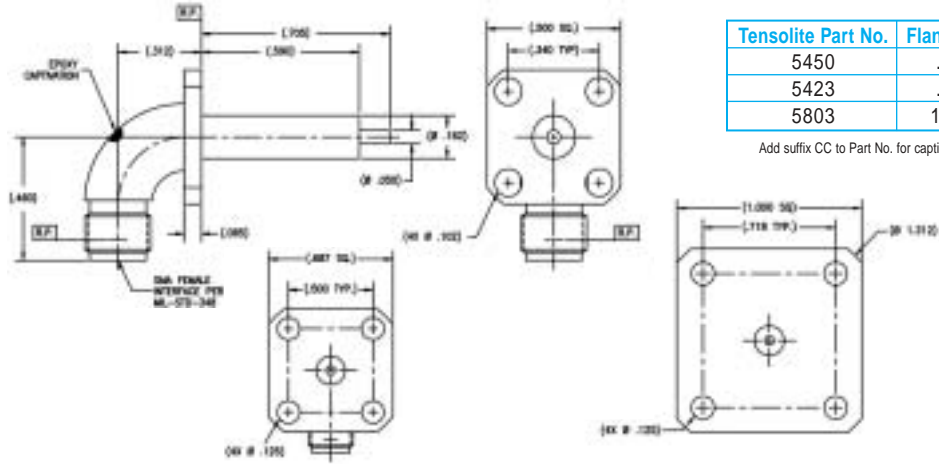

Tensolite Part No.	Flange Size
5450	.500
5423	.687
5803	1.000

Add suffix CC to Part No. for captivated contact.

## 5901

Radius right angle flange mount male

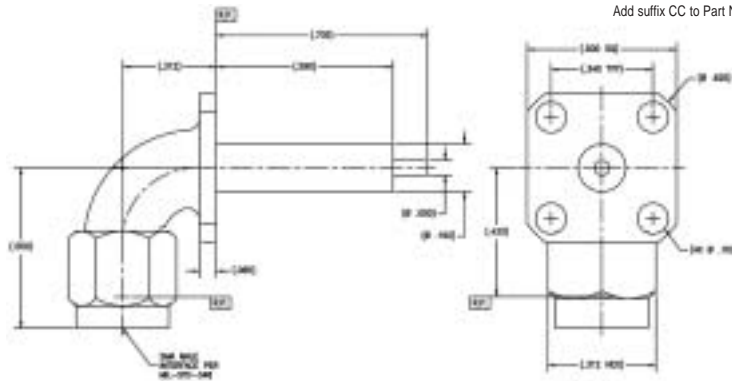

Add suffix CC to Part No. for captivated contact.

## 5648, 5649

Radius right angle two-hole flange mount female

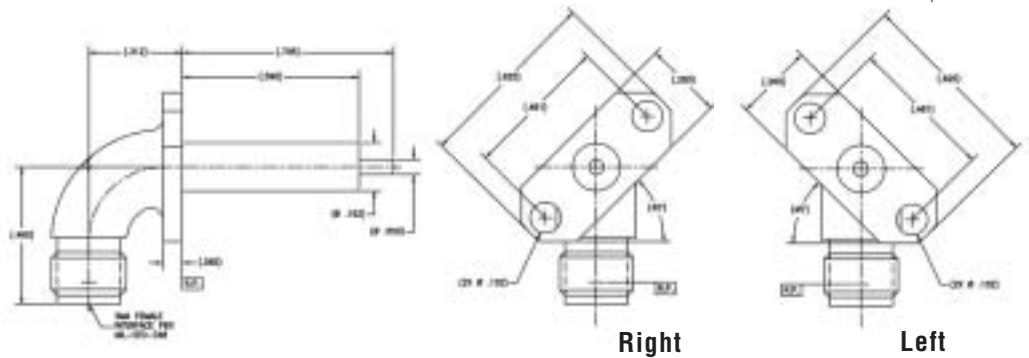

Tensolite Part No.	Flange Angle
5648	.45° Right
5649	.45° Left

Add suffix CC to Part No. for captivated contact.

## 5617, 5618

Radius right angle two-hole flange mount male

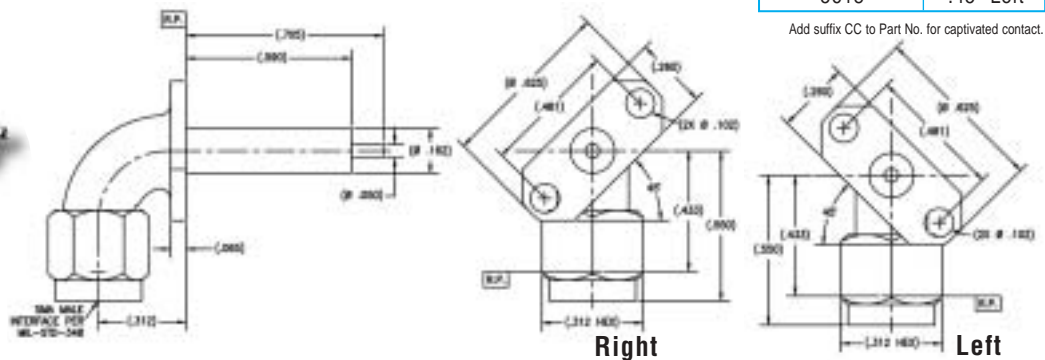

Tensolite Part No.	Flange Angle
5617	.45° Right
5618	.45° Left

Add suffix CC to Part No. for captivated contact.



# SMA Bulkhead & Panel Mount Slotted Terminations

## 5698, 5700

Flange mount female

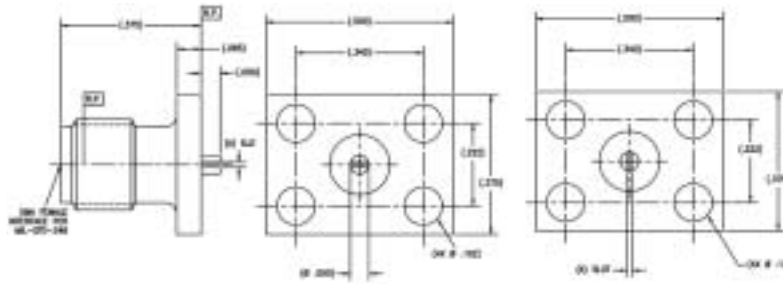

Horizontal

Vertical

Tensolite Part No.	"A" Slot +.003/- .001	Slot Position
5698-1	.012	horizontal
5698-2	.018	horizontal
5698-3	.028	horizontal
5698-4	.036	horizontal
5700-1	.012	vertical
5700-2	.018	vertical
5700-3	.028	vertical
5700-4	.036	vertical

Add suffix CC to Part No. for captivated contact.

## 5710, 5712

Flange mount male

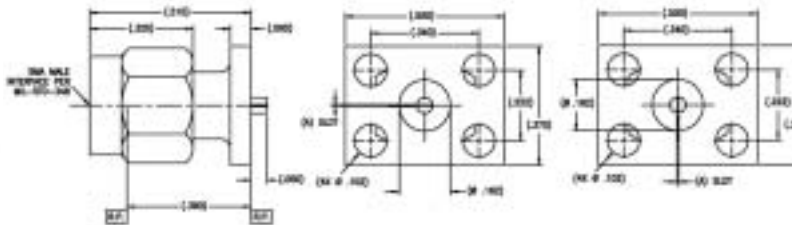

Horizontal

Vertical

Tensolite Part No.	"A" Slot +.003/- .001	Slot Position
5710-1	.012	horizontal
5710-2	.018	horizontal
5710-3	.028	horizontal
5710-4	.036	horizontal
5712-1	.012	vertical
5712-2	.018	vertical
5712-3	.028	vertical
5712-4	.036	vertical

Add suffix CC to Part No. for captivated contact.

## 5208, 5209

Two-hole flange mount female

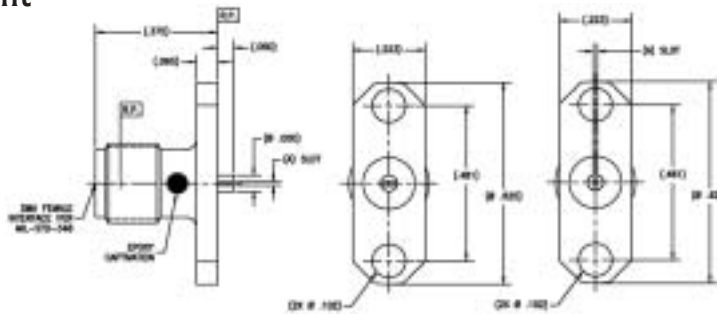

Horizontal

Vertical

Tensolite Part No.	"A" Slot +.003/- .001	Slot Position
5208-1	.012	horizontal
5208-2	.018	horizontal
5208-3	.028	horizontal
5208-4	.036	horizontal
5209-1	.012	vertical
5209-2	.018	vertical
5209-3	.028	vertical
5209-4	.036	vertical

Add suffix CC to Part No. for captivated contact.

## 5205, 5206

Two-hole flange mount male

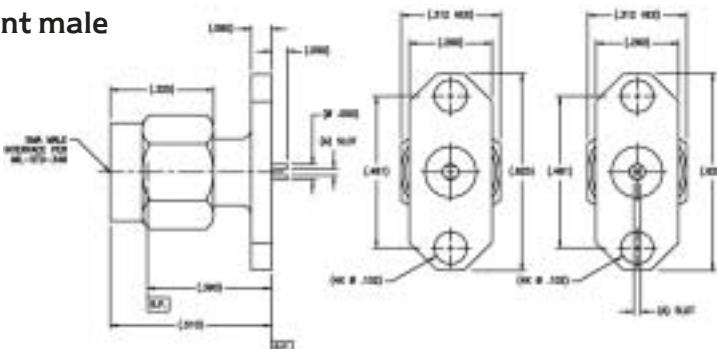

Horizontal

Vertical

Tensolite Part No.	"A" Slot +.003/- .001	Slot Position
5205-1	.012	horizontal
5205-2	.018	horizontal
5205-3	.028	horizontal
5205-4	.036	horizontal
5206-1	.012	vertical
5206-2	.018	vertical
5206-3	.028	vertical
5206-4	.036	vertical

Add suffix CC to Part No. for captivated contact.



# SMA Bulkhead & Panel Mount Slotted Terminations

## 5230

Two-hole flange mount female

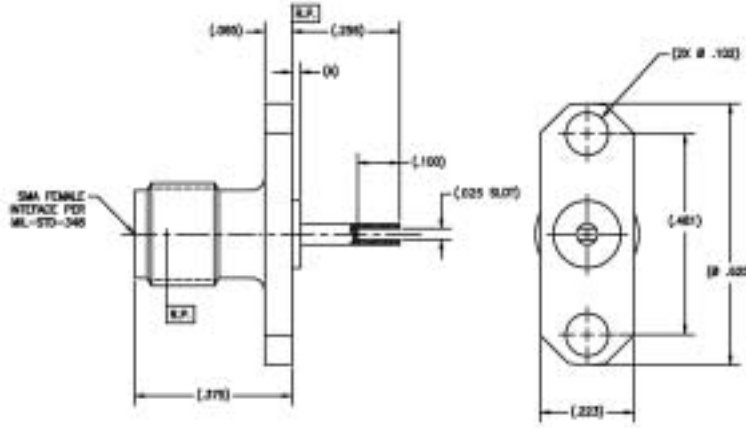

Tensolite Part No.	"A"
5230-1	.000
5230-2	.020
5230-3	.030

Add suffix CC to Part No. for captivated contact.

## 5580, 5581

Radius right angle flange mount female

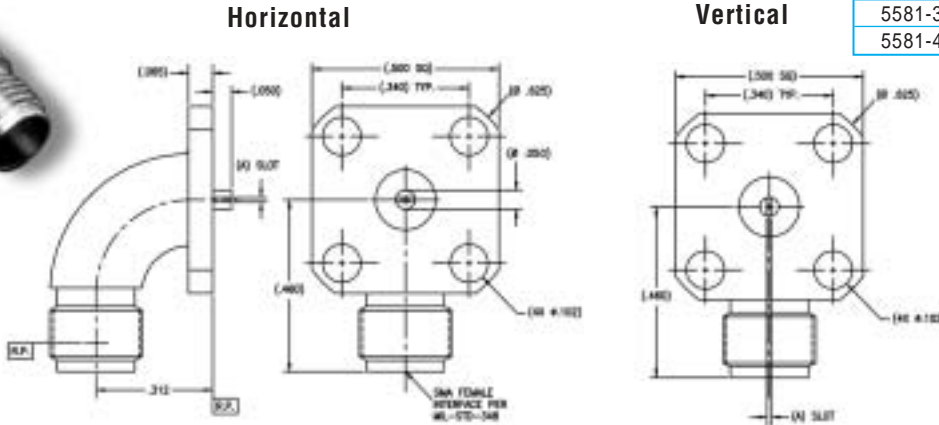

Tensolite Part No.	"A" Slot +.003/-0.001	Slot Position
5580-1	.012	horizontal
5580-2	.018	horizontal
5580-3	.028	horizontal
5580-4	.036	horizontal
5581-1	.012	vertical
5581-2	.018	vertical
5581-3	.028	vertical
5581-4	.036	vertical

Add suffix CC to Part No. for captivated contact.

## 5595, 5596

Radius right angle flange mount female

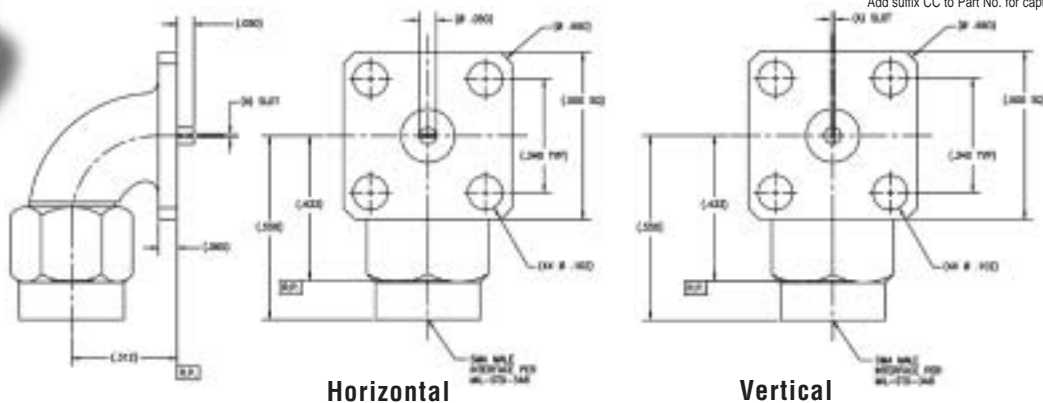

Tensolite Part No.	"A" Slot +.003/-0.001	Slot Position
5595-1	.012	horizontal
5595-2	.018	horizontal
5595-3	.028	horizontal
5595-4	.036	horizontal
5596-1	.012	vertical
5596-2	.018	vertical
5596-3	.028	vertical
5596-4	.036	vertical

Add suffix CC to Part No. for captivated contact.



# SMA Bulkhead & Panel Mount Slotted Terminations

## 5654, 5655, 5657, 5658

Radius right angle two-hole flange mount female

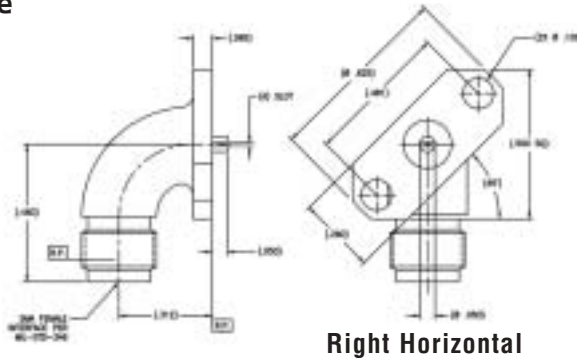

Tensolite Part No.	"A" Slot +.003/-0.001	Flange Angle	Slot Position
5654-1	.012	45° right	Horizontal
5654-2	.018	45° right	Horizontal
5654-3	.028	45° right	Horizontal
5654-4	.036	45° right	Horizontal
5655-1	.012	45° left	Horizontal
5655-2	.018	45° left	Horizontal
5655-3	.028	45° left	Horizontal
5655-4	.036	45° left	Horizontal
5657-1	.012	45° right	Vertical
5657-2	.018	45° right	Vertical
5657-3	.028	45° right	Vertical
5657-4	.036	45° right	Vertical
5658-1	.012	45° left	Vertical
5658-2	.018	45° left	Vertical
5658-3	.028	45° left	Vertical
5658-4	.036	45° left	Vertical

Add suffix CC to Part No. for captivated contact.

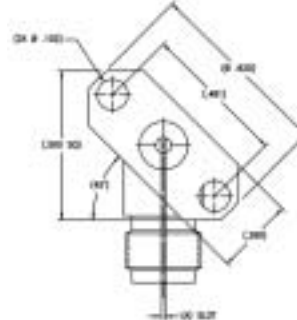
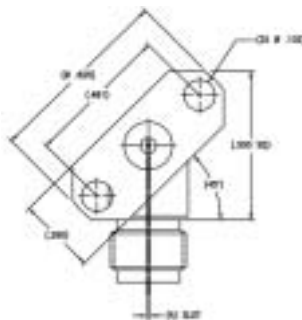
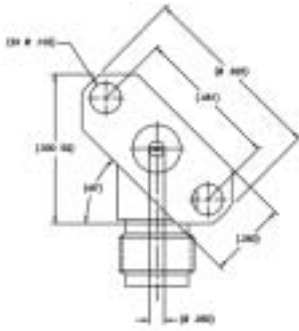

## 5626, 5627, 5629, 5630

Radius right angle two-hole flange mount male

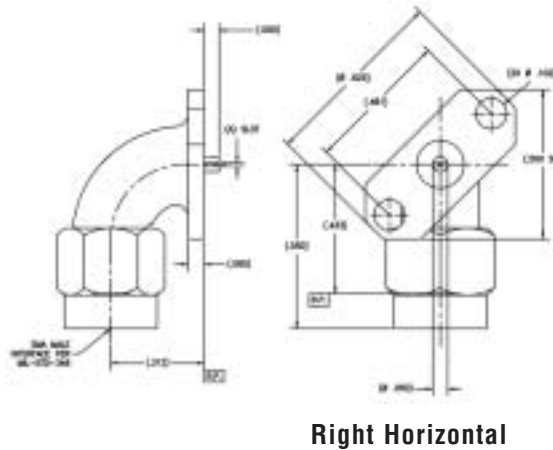

Tensolite Part No.	"A" Slot +.003/-0.001	Flange Angle	Slot Position
5626-1	.012	45° right	Horizontal
5626-2	.018	45° right	Horizontal
5626-3	.028	45° right	Horizontal
5626-4	.036	45° right	Horizontal
5627-1	.012	45° left	Horizontal
5627-2	.018	45° left	Horizontal
5627-3	.028	45° left	Horizontal
5627-4	.036	45° left	Horizontal
5629-1	.012	45° right	Vertical
5629-2	.018	45° right	Vertical
5629-3	.028	45° right	Vertical
5629-4	.036	45° right	Vertical
5630-1	.012	45° left	Vertical
5630-2	.018	45° left	Vertical
5630-3	.028	45° left	Vertical
5630-4	.036	45° left	Vertical

Add suffix CC to Part No. for captivated contact.

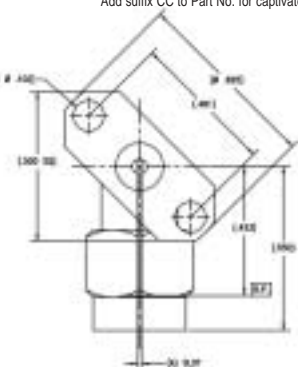
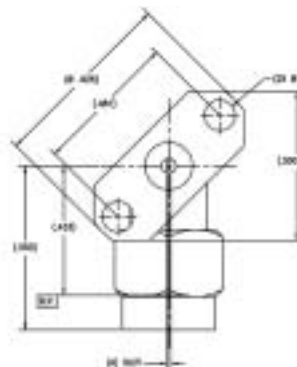



# SMA Bulkhead & Panel Mount Tab Terminations

## 5922, 5762, 5271, 5276

Flange mount female

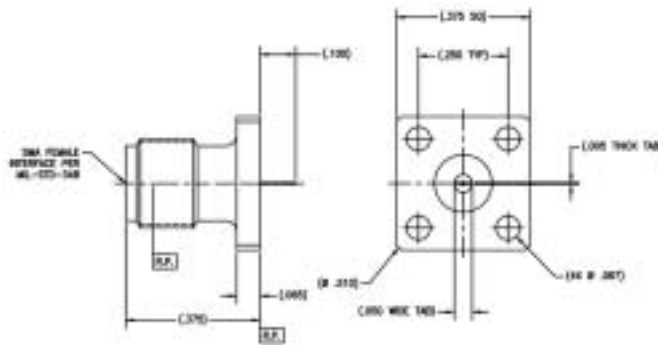

Tensolite Part No.	Flange Size
5922	.375
5762	.500
5271	.687
5276	1.000

Add suffix CC to Part No. for captivated contact.

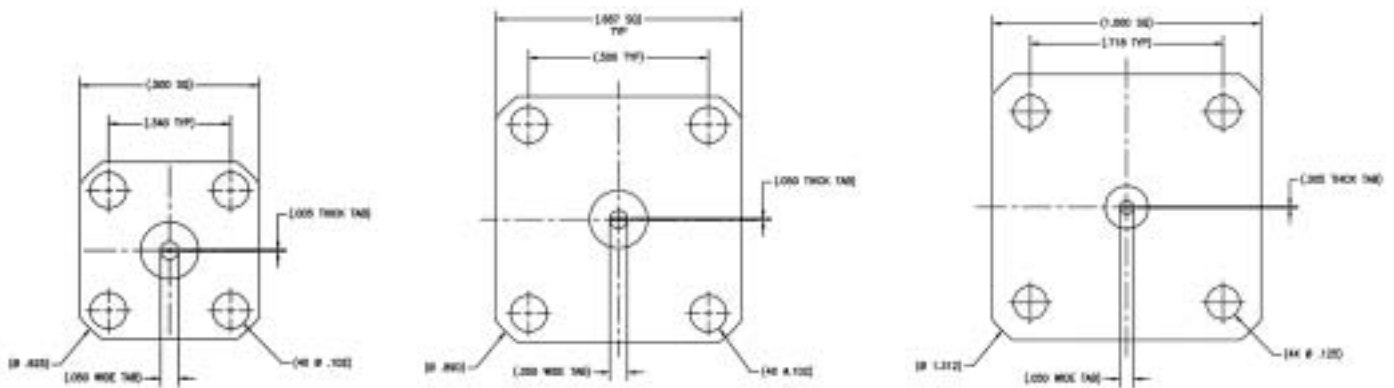

## 5930, 5348, 5357, 5352

Flange mount male

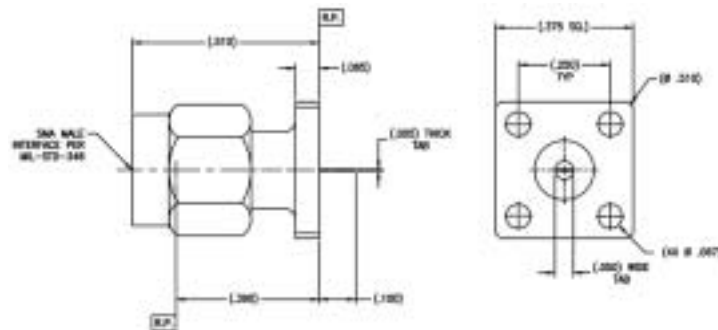

Tensolite Part No.	Flange Size
5930	.375
5348	.500
5357	.687
5352	1.000

Add suffix CC to Part No. for captivated contact.

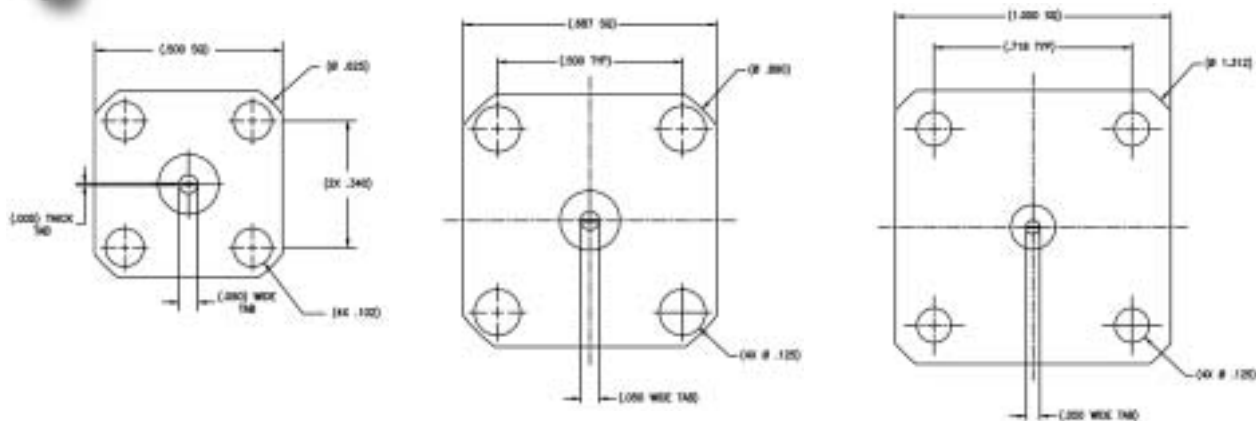

# SMA Bulkhead & Panel Mount Tab Terminations

Add suffix CC to Part No. for captivated contact.

## 5763

Flange mount female  
.020 wide tab

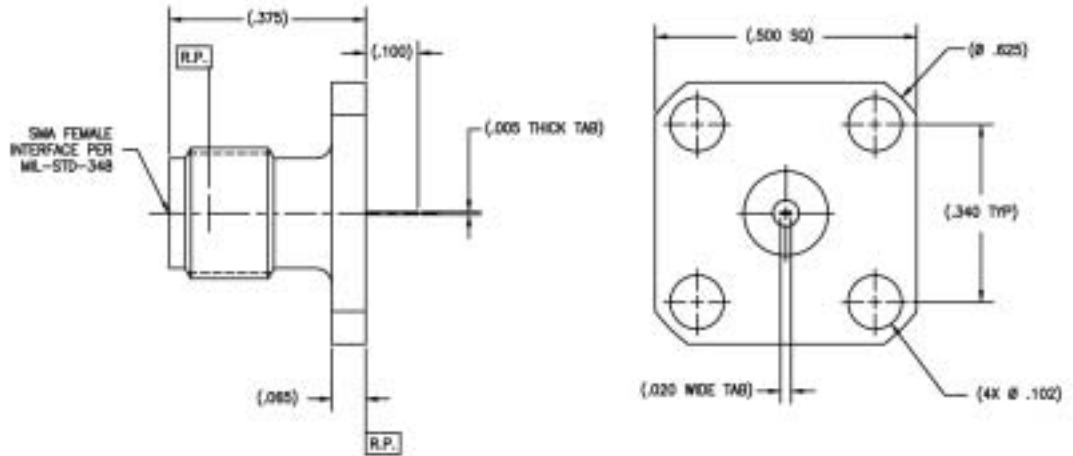

## 5460, 5461

Radius right angle  
flange mount female

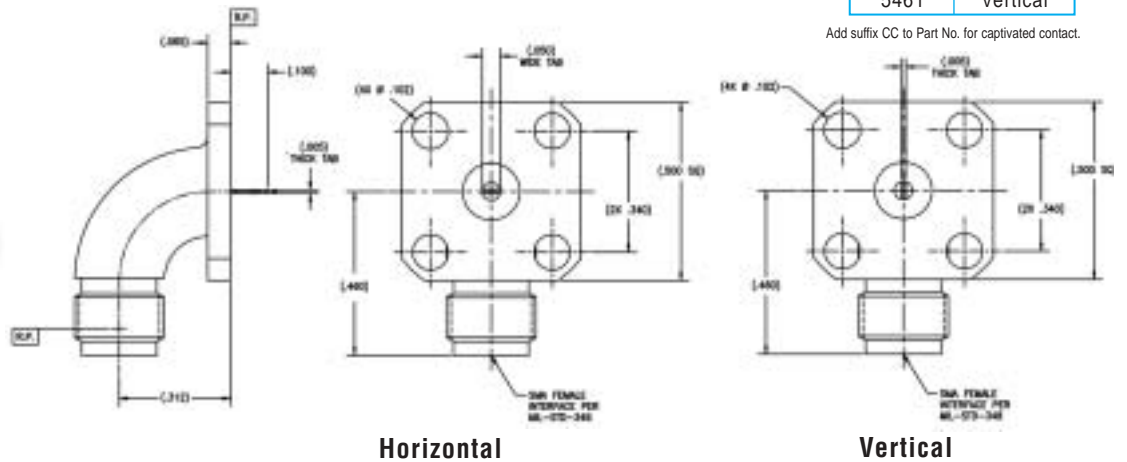

Add suffix CC to Part No. for captivated contact.

## 5880, 5881

Radius right angle  
flange mount male

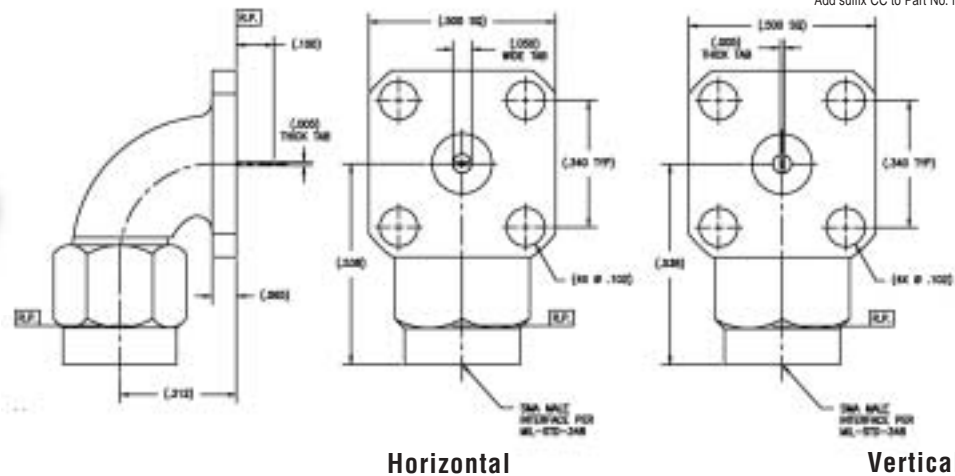

Add suffix CC to Part No. for captivated contact.



# SMA Bulkhead & Panel Mount Tab Terminations

## 5645, 5646, 5651, 5652

Radius right angle two  
hole flange female

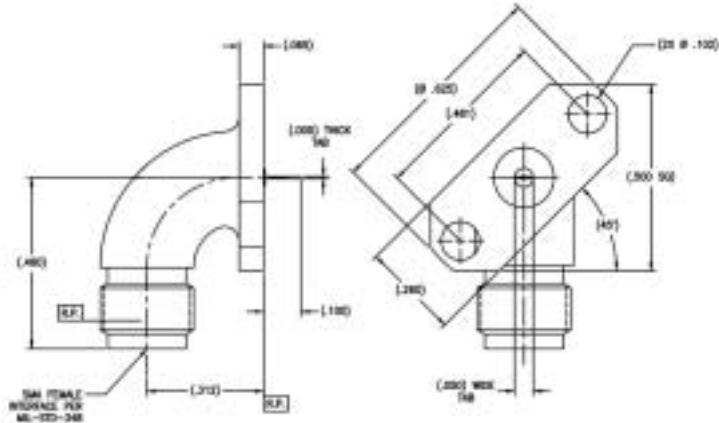

Tensolite Part No.	Flange Angle	Tab Position
5645	45° Right	Horizontal
5646	45° Left	Horizontal
5651	45° Right	Vertical
5652	45° Left	Vertical

Add suffix CC to Part No. for captivated contact.

Right Horizontal

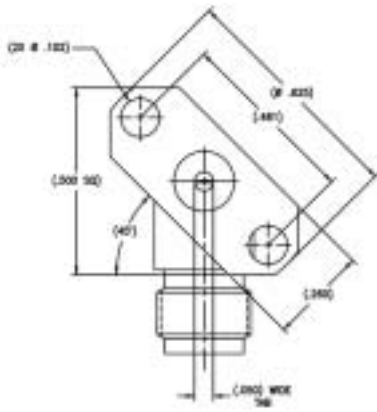

Left Horizontal

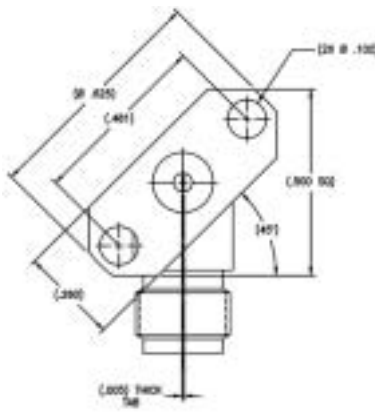

Right Vertical

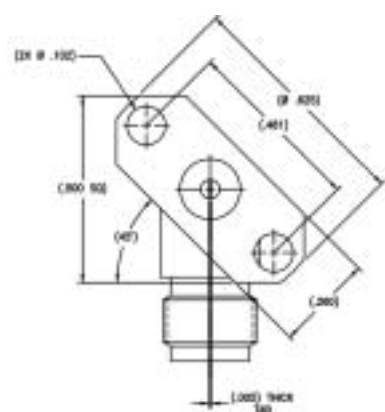

Left Vertical

## 5623, 5624, 5614, 5615

Radius right angle two  
hole flange male

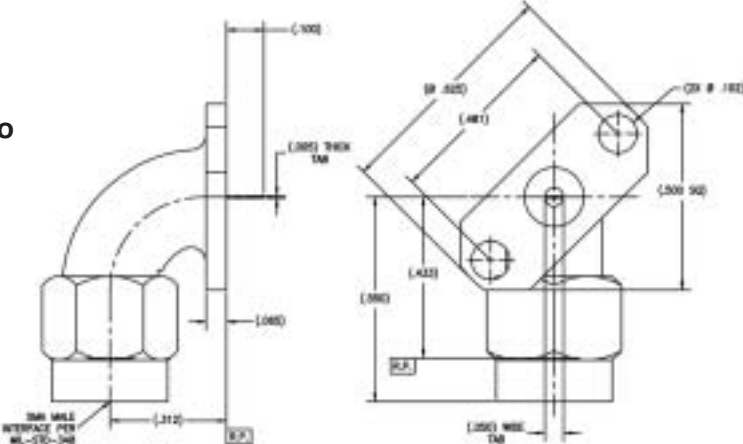

Tensolite Part No.	Flange Angle	Tab Position
5623	45° Right	Horizontal
5624	45° Left	Horizontal
5614	45° Right	Vertical
5615	45° Left	Vertical

Add suffix CC to Part No. for captivated contact.

Right Horizontal

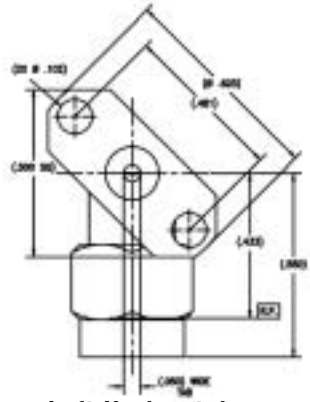

Left Horizontal

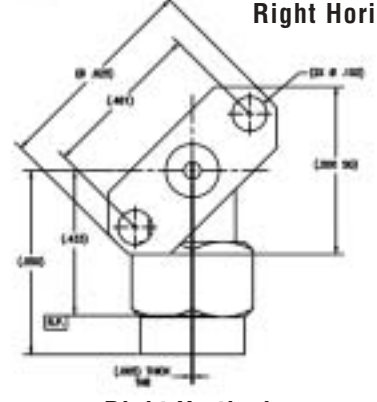

Right Vertical

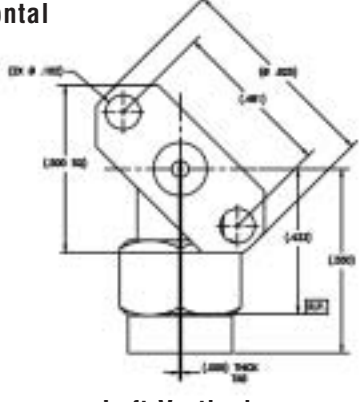

Left Vertical



# SMA Bulkhead & Panel Mount Tab Terminations

## 5692, 5694

Rectangular flange mount female

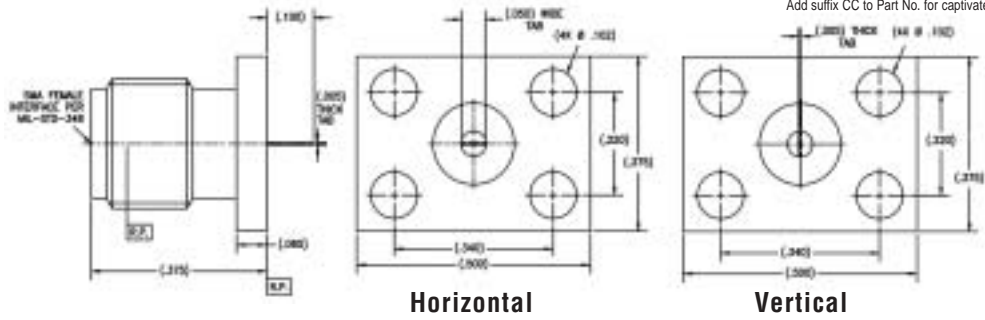

Tensolite Part No.	Tab Position
5692	Horizontal
5694	Vertical

Add suffix CC to Part No. for captivated contact.

## 5704, 5706

Rectangular flange mount male

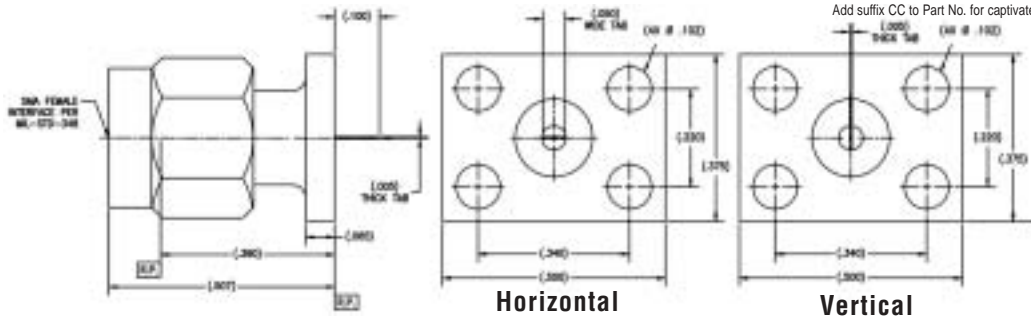

Tensolite Part No.	Tab Position
5704	Horizontal
5706	Vertical

Add suffix CC to Part No. for captivated contact.

## 5250, 5251

Two hole flange mount female

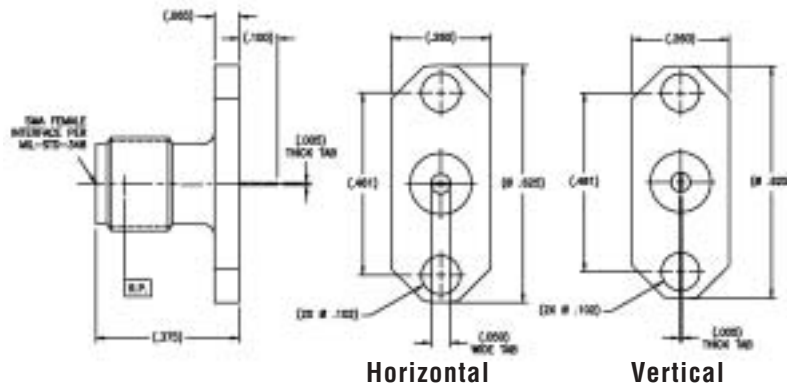

Tensolite Part No.	Tab Position
5250	Horizontal
5251	Vertical

Add suffix CC to Part No. for captivated contact.

## 5343, 5344

Two hole flange mount male

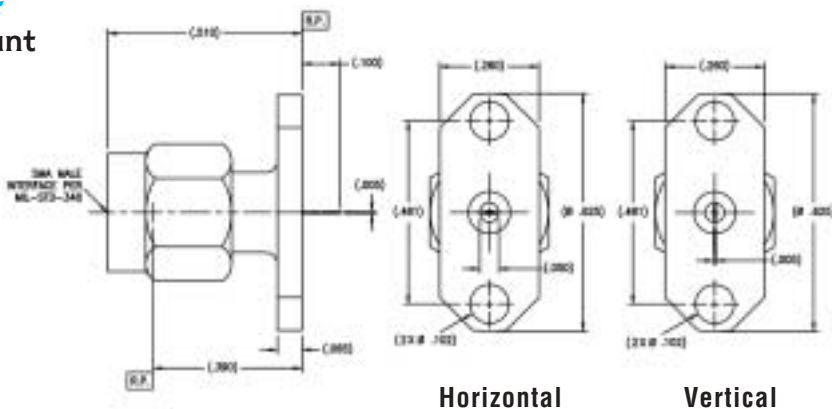

Tensolite Part No.	Tab Position
5343	Horizontal
5344	Vertical

Add suffix CC to Part No. for captivated contact.

SMA Bulkhead & Panel Mount Tab Terminations

# SMA Bulkhead & Panel Mount Female Contact Terminations (Field Replaceables)

SMA Bulkhead & Panel Mount Female Contact Terminations (Field Replaceables)

## Flange mount female airsection design style



Tensolite Part No. with gasket	Tensolite Part No. w/o gasket	Flange Size	Fig.			
5601-	5674-	2 hole, .187 x .550	A			
5685-	5681-	2 hole, .223 x .625	B			
5935-	5923-	4 hole, .375 x .375	C			
5715-	5717-	4 hole, .375 x .500	D			
5684-	5680-	4 hole, .500 x .500	E			
Select -1CC thru -6CC size female contact to accept "A" diameter pin x 0.090 long						
Dash No.	-1CC	-2CC	-3CC	-4CC	-5CC	-6CC
"A" ± .001	.0360	.0200	.0100	.0120	.0150	.0180

Center conductor is mechanically captivated.

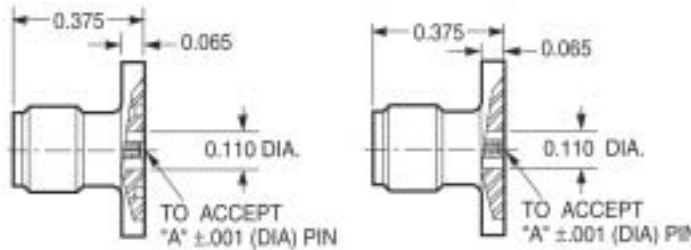

With Conductive Gasket

Without Conductive Gasket

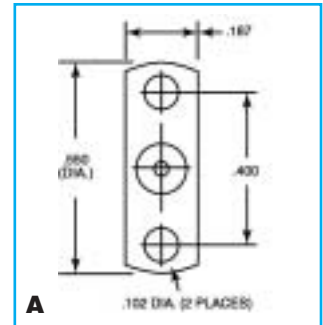

A

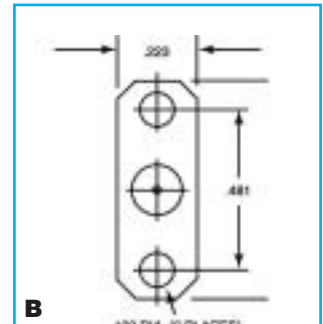

B

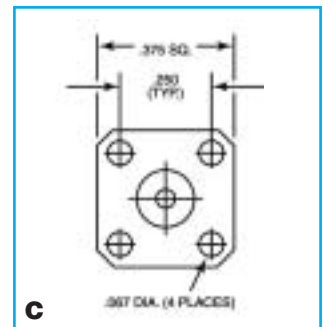

C

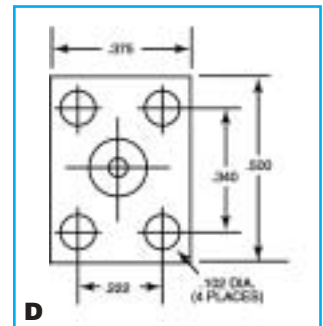

D

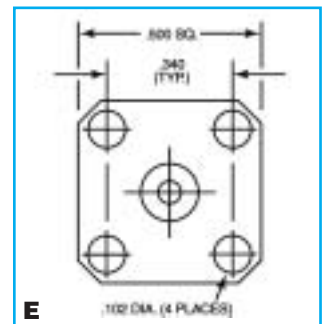

E

## Flange mount male airsection design style



Tensolite Part No. with gasket	Tensolite Part No. w/o gasket	Flange Size	Fig.			
5633-	5675-	2 hole, .187 x .550	A			
5687-	5683-	2 hole, .223 x .625	B			
5936-	5925-	4 hole, .375 x .375	C			
5716-	5718-	4 hole, .375 x .500	D			
5686-	5780-	4 hole, .500 x .500	E			
Select -1CC thru -6CC size female contact to accept "A" diameter pin x 0.090 long						
Dash No.	-1CC	-2CC	-3CC	-4CC	-5CC	-6CC
"A" ± .001	.0360	.0200	.0100	.0120	.0150	.0180

Center conductor is mechanically captivated.

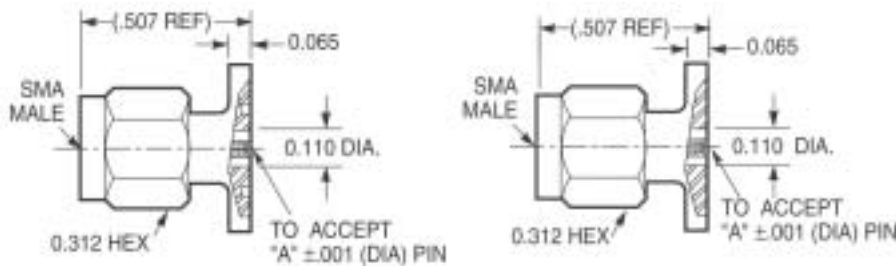

With Conductive Gasket

Without Conductive Gasket

# SMA Bulkhead & Panel Mount Female Contact Terminations (Field Replaceables)

Flange mount female flush PTFE design style (mechanical captivation)



Tensolite Part No. with gasket	Tensolite Part No. w/o gasket	Flange Size	Fig.
5634-	5678-	2 hole, .187 x .550	A
5602-	5663-	2 hole, .223 x .625	B
5603-	5941-	4 hole, .375 x .375	C
5605-	5668-	4 hole, .375 x .500	D
5604-	5665-	4 hole, .500 x .500	E

Select -2CC thru -6CC size female contact to accept "A" diameter pin x 0.090 long

Dash No.	-2CC	-3CC	-4CC	-5CC	-6CC
"A" ±.001	.0200	.0100	.0120	.0150	.0180

Center conductor is mechanically captivated.

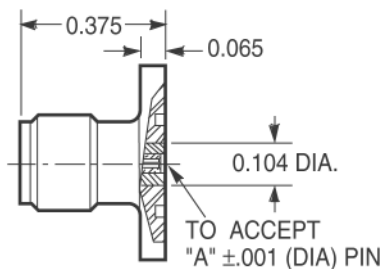

With Conductive Gasket

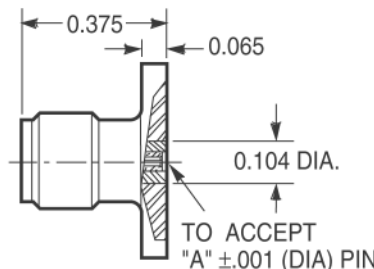

Without Conductive Gasket

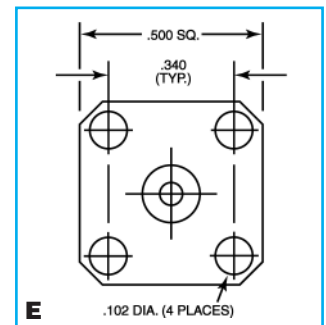
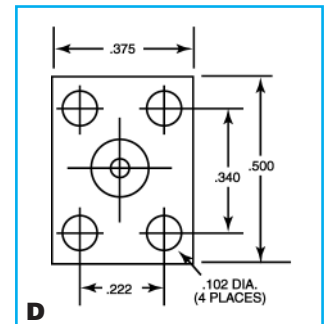
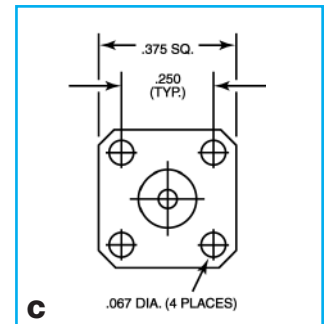
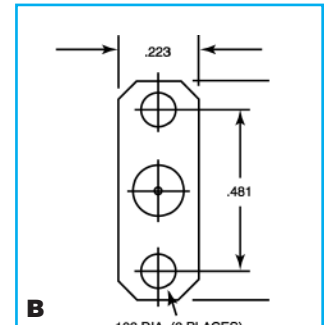
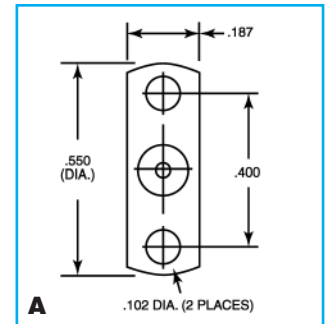

Flange mount male flush PTFE design style (mechanical captivation)

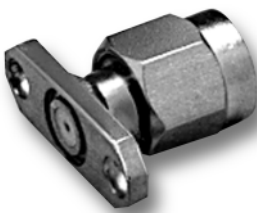

Tensolite Part No. with gasket	Tensolite Part No. w/o gasket	Flange Size	Fig.
5635-	5679-	2 hole, .187 x .550	A
5606-	5664-	2 hole, .223 x .625	B
5607-	5942-	4 hole, .375 x .375	C
5609-	5669-	4 hole, .375 x .500	D
5608-	5666-	4 hole, .500 x .500	E

Select -2CC thru -6CC size female contact to accept "A" diameter pin x 0.090 long

Dash No.	-2CC	-3CC	-4CC	-5CC	-6CC
"A" ±.001	.0200	.0100	.0120	.0150	.0180

Center conductor is mechanically captivated.

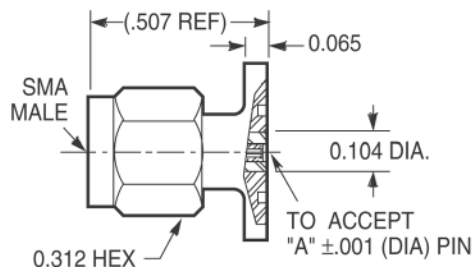

With Conductive Gasket

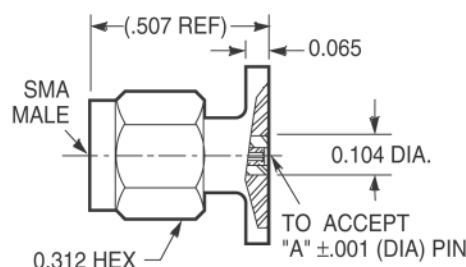

Without Conductive Gasket

# SMA Bulkhead & Panel Mount Female Contact Terminations (Field Replaceables)

SMA Bulkhead & Panel Mount Female Contact Terminations (Field Replaceables)

## Flange mount female flush PTFE design style

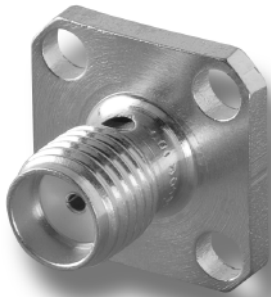

Tensolite Part No. with gasket	Tensolite Part No. w/o gasket	Flange Size	Fig.			
N/A	N/A	2 hole, .187 x .550	A			
N/A	5981-	2 hole, .223 x .625	B			
N/A	5937-	4 hole, .375 x .375	C			
N/A	5734-	4 hole, .375 x .500	D			
N/A	5980-	4 hole, .500 x .500	E			
Select -1CC thru -6CC size female contact to accept "A" diameter pin x 0.090 long						
Dash No.	-1CC	-2CC	-3CC	-4CC	-5CC	-6CC
"A" ± .001	.0360	.0200	.0100	.0120	.0150	.0180

Center conductor is epoxy captivated.

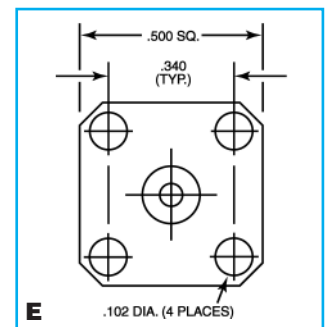
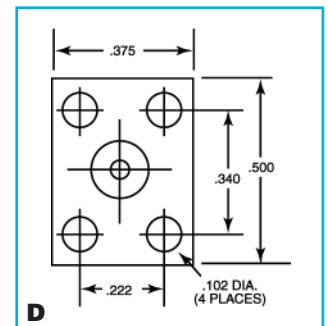
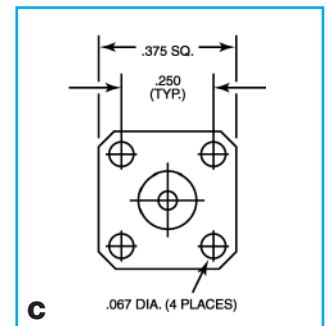
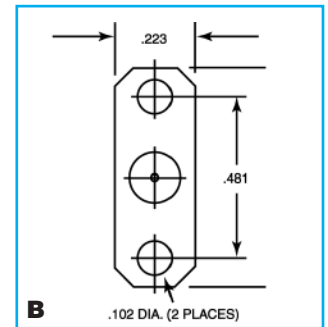
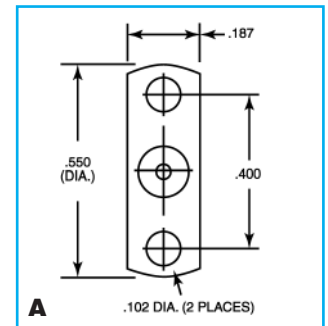
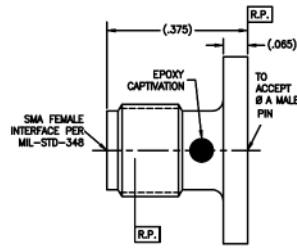

## Flange mount male flush PTFE design style



Tensolite Part No. with gasket	Tensolite Part No. w/o gasket	Flange Size	Fig.			
N/A	N/A	2 hole, .187 x .550	A			
N/A	5983-	2 hole, .223 x .625	B			
N/A	5938-	4 hole, .375 x .375	C			
N/A	5714-	4 hole, .375 x .500	D			
N/A	5982-	4 hole, .500 x .500	E			
Select -1CC thru -6CC size female contact to accept "A" diameter pin x 0.090 long						
Dash No.	-1CC	-2CC	-3CC	-4CC	-5CC	-6CC
"A" ± .001	.0360	.0200	.0100	.0120	.0150	.0180

Center conductor is epoxy captivated.

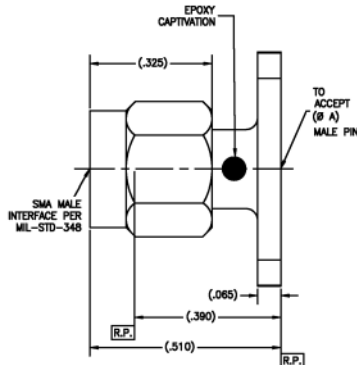



# SMA Bulkhead & Panel Mount Female Contact Terminations

## 5530

Radius right angle  
flange mount female

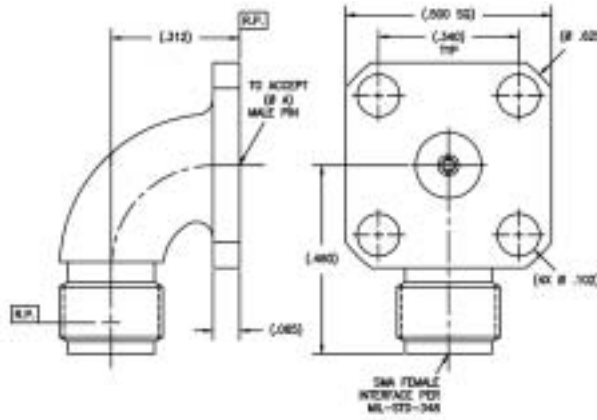

Tensolite Part No.	"A" ± .001
5530-1CC	.0360
5530-2CC	.0200
5530-3CC	.0100

Center conductor is captivated.

## 5659, 5660

Radius right angle two hole  
flange mount female

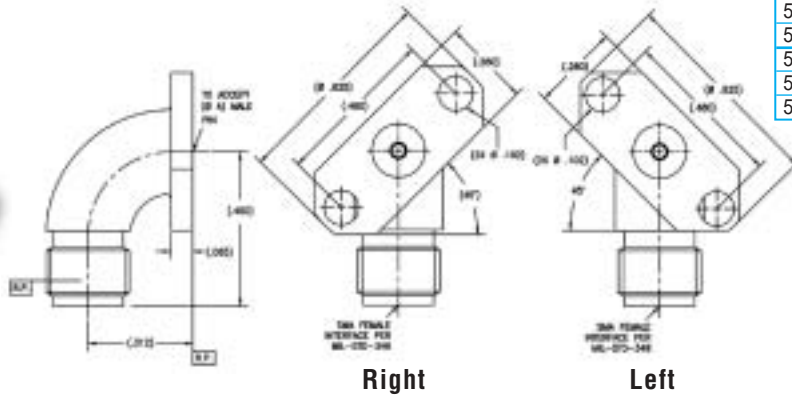

Tensolite Part No.	"A" ± .001	Flange Position
5659-1CC	.0360	45° Left
5659-2CC	.0200	45° Left
5659-3CC	.0100	45° Left
5660-1CC	.0100	45° Right
5660-2CC	.0100	45° Right
5660-3CC	.0100	45° Right

Center conductor is captivated.

## 5902

Radius right angle  
flange mount male

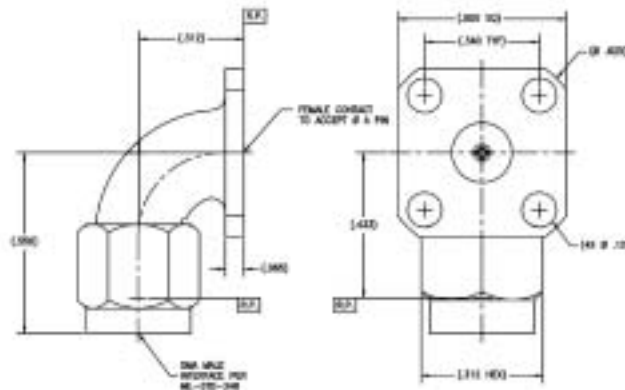

Tensolite Part No.	"A" ± .001
5902-1CC	.0360
5902-2CC	.0200
5902-3CC	.0100

Center conductor is captivated.

## 5631, 5632

Radius right angle two hole  
flange mount male

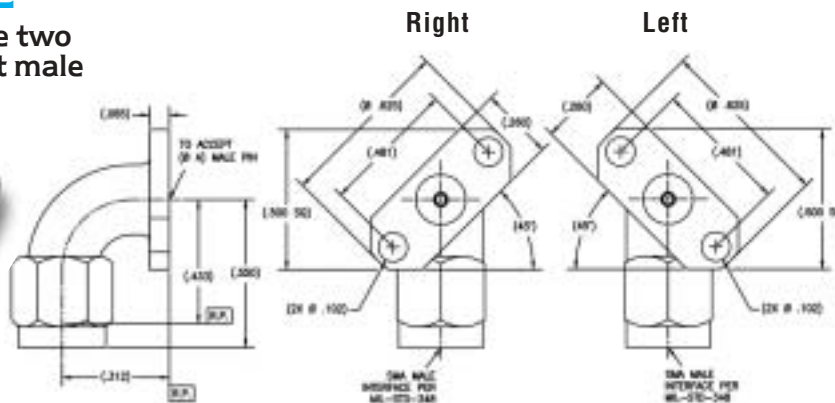

Tensolite Part No.	"A" ± .001	Flange Position
5631-1CC	.0360	45° Right
5631-2CC	.0200	45° Right
5631-3CC	.0100	45° Right
5632-1CC	.0360	45° Left
5632-2CC	.0200	45° Left
5632-3CC	.0100	45° Left

Center conductor is captivated.



# SMA Bulkhead & Panel Mount Female Contact Terminations

## 1345-1

Center conductor

Tensolite Part No.	"A"	"B"
1345-1	.036	.020
1345-2	.036	.050
1345	.020	.020

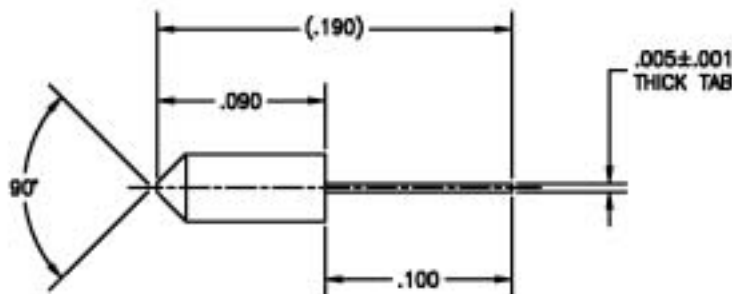

# SMA EMI/RFI Gaskets

## 1604-11

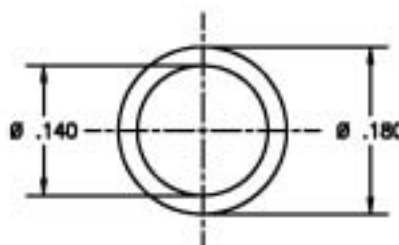

Tensolite Part No.	"A"	"B"
1604-11	.180	.140

Material: Conductive Silver/Silicone Elastomers

# SMA Solder and Braze-in Hermetic Seal

## 4004



Tensolite Part No.	"A"	"B"	"C"	"D"	"E"	"F"
4004-5	.0120±.0005	.078 (REF.)	.0985±.0015	.079/.065	.0625±.0025	.180
4004-9	.0150±.0005	.082 (REF.)	.0985±.0015	.079/.065	.0630±.0025	.180
4004-11	.0180±.0005	.099 (REF.)	.1115±.0015	.079/.065	.0625±.0025	.180
4004-13	.0200±.0005	.129 (REF.)	.1580±.0015	.067/.053	.0625±.0025	.205

Glass Seal Assembly Material and Finishes:  
Outer Ring & Pin: Kovar, gold plated per MIL-G-45204, Type II, Class I, Grade C  
Glass Bead: #7052

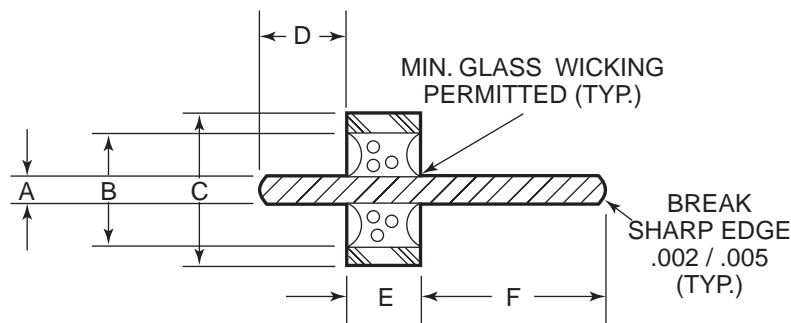

# SMA Bulkhead & Panel Mount Hermetically Sealed Connectors

## 5961CC, 5962CC, 5964CC, 5967CC

Bulkhead feed through female  
hermetically sealed

Tensolite Part No.	Ø "A"	"B"	"C"	"D"
5961CC	.028	.080	.040	.451
5962CC	.028	.080	.040	.451
5964CC	.064	.080	.040	.451
5967CC	.020	.115	—	.500

Center contact is captivated.



5964CC

### 5961CC

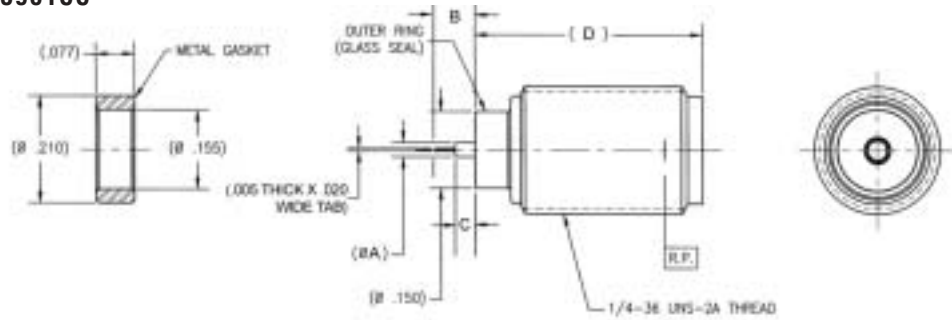

### 5962CC

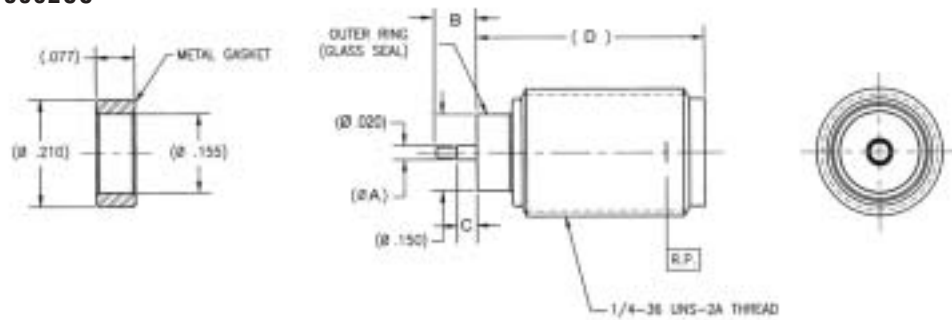

### 5964CC

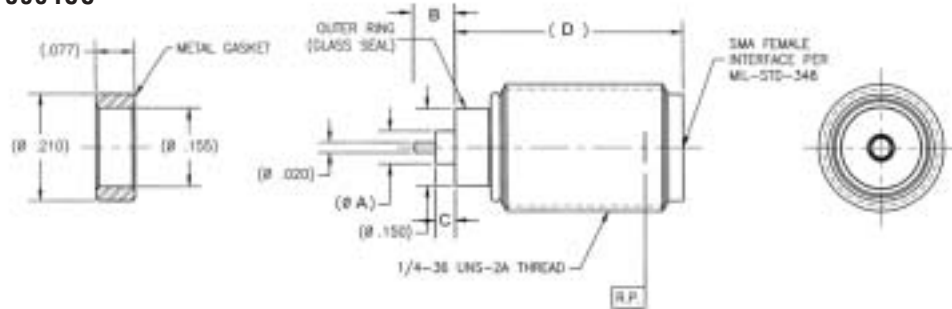

### 5967CC

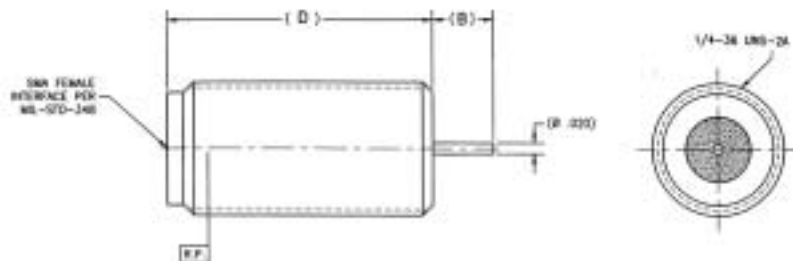

SMA Bulkhead & Panel Mount Hermetically Sealed Connectors

# SMA Bulkhead & Panel Mount Hermetically Sealed Connectors

## 5971CC, 5972

Flange mount SMA female hermetically sealed

Tensolite Part No.	"A"	"B"
5971CC	—	.490
5972-1CC	.093	.583
5972-2CC	.125	.615
5972-3CC	.187	.677

Center contact is captivated.



5971CC

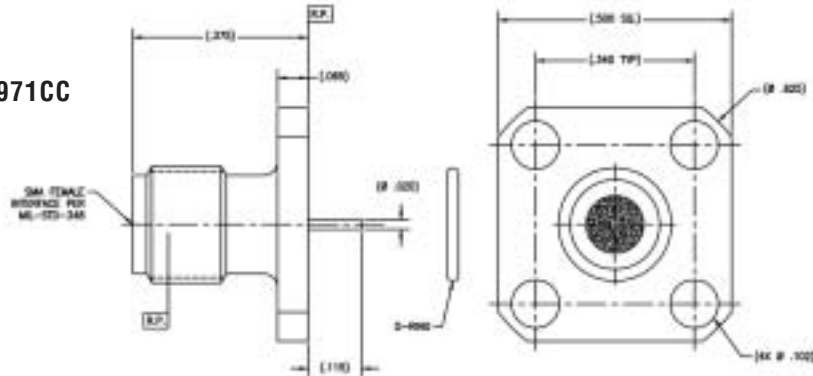

5972CC

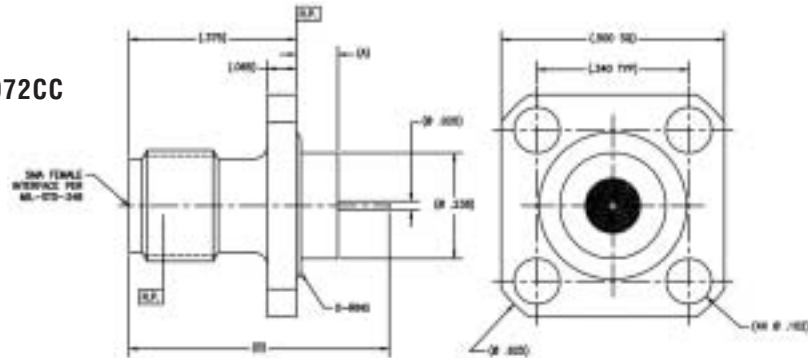

# SMA Strip Transmission Line Terminations

## 5246

Edge mount female stripline

Tensolite Part No.	"A"	"B"
5246-1	.062	.025
5246-2	.125	.050
5246-3	.250	.050

Add suffix CC to part number for captivated contact.

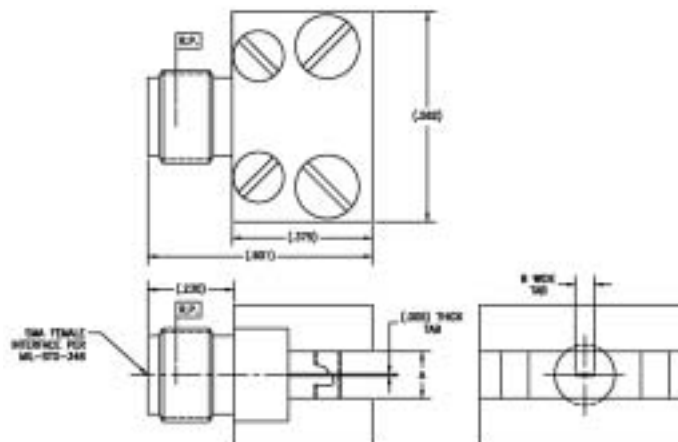

# SMA Strip Transmission Line Terminations

## 5361

Edge mount male stripline

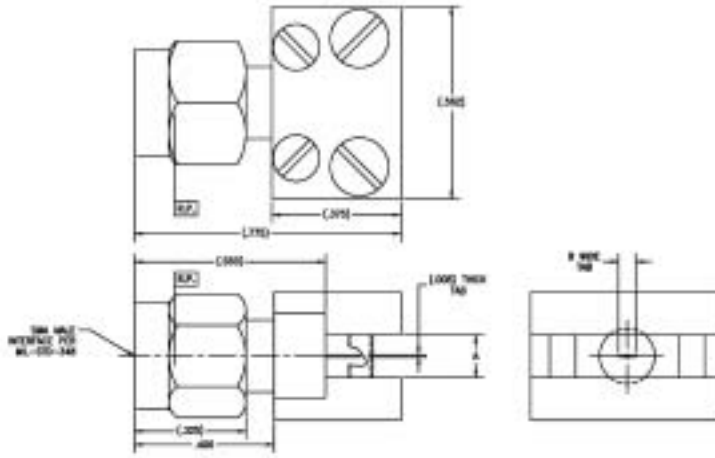

Tensolite Part No.	"A"	"B"
5361-1	.062	.025
5361-2	.125	.050
5361-3	.250	.050

Add suffix CC to part number for captivated contact.

## 5240

Surface mount female stripline

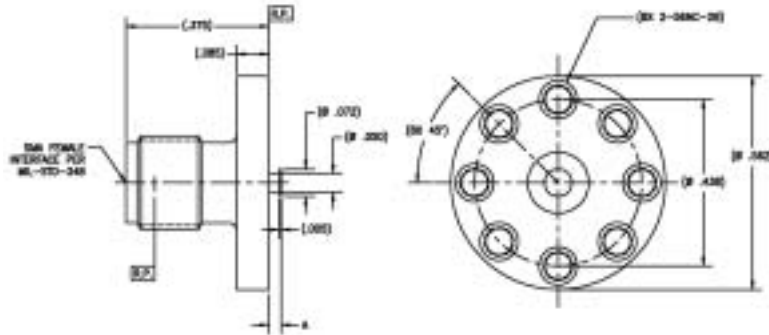

Tensolite Part No.	"A"
5240-1	.032
5240-2	.062
5240-3	.094
5240-4	.125

## 5320

Surface mount male stripline

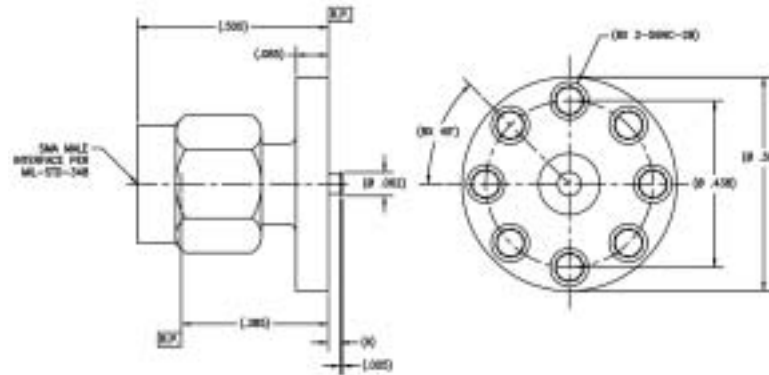

Tensolite Part No.	"A"
5320-1	.032
5320-2	.062
5320-3	.094
5320-4	.125





# SMA Microstrip Transmission Line Terminations

## 5308

Flange mount female

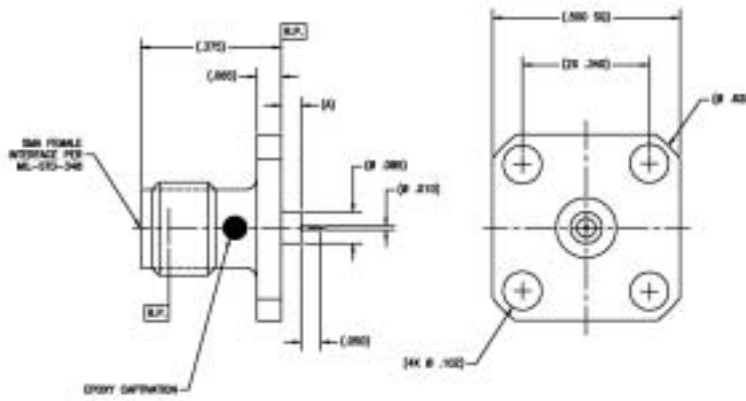

Tensolite Part No.	"A"
5308-1CC	.057
5308-2CC	.125

Center conductor is captivated.

## 5309

Two hole flange mount female

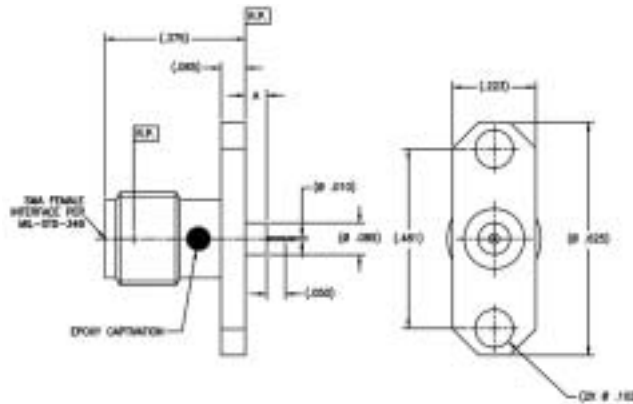

Tensolite Part No.	"A"
5309-1CC	.057
5309-2CC	.125

Center conductor is captivated.

## 5860

Flange mount female

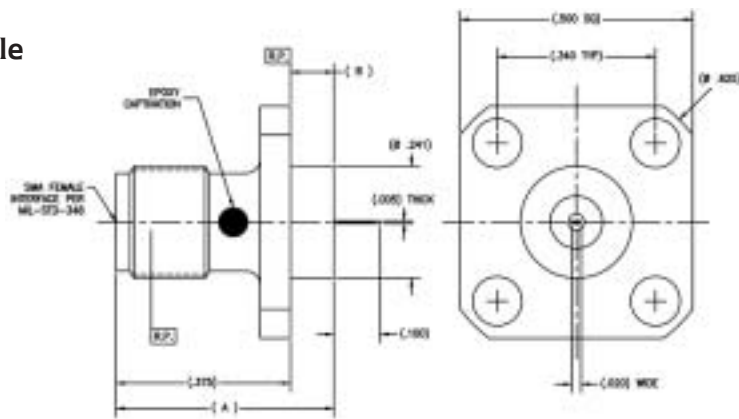

Tensolite Part No.	"A"	"B"
5860-1CC	.568	.093
5860-2CC	.600	.125
5860-3CC	.662	.187

Center conductor is captivated.

## 5861

Flange mount male

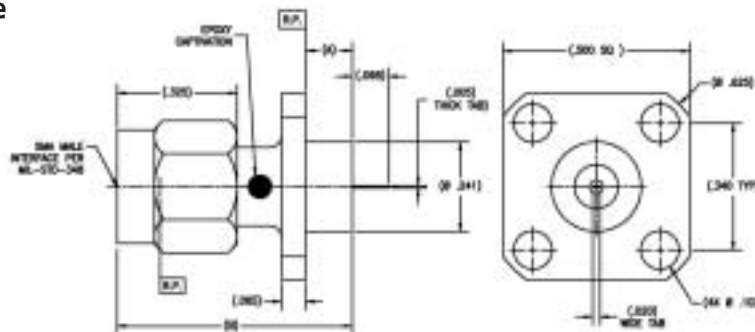

Tensolite Part No.	"A"	"B"
5861-1CC	.700	.093
5861-2CC	.732	.125
5861-3CC	.794	.187

Center conductor is captivated.